

ALTERNATOR & REGULATOR - HITACHI

1990 Nissan 240SX

1990-91 ELECTRICAL
Alternators & Regulators - Hitachi

1990 Axxess, Pulsar NX
1991 Maxima, NX, Pathfinder, Pickup, Sentra,
Stanza, 240SX & 300ZX

NOTE: Some models are available with Mitsubishi alternators. See appropriate ALTERNATOR & REGULATOR - MITSUBISHI article.

DESCRIPTION

Hitachi alternators are conventional 3-phase, self-rectifying alternators. See Fig. 3. Three positive and 3 negative diodes are used to rectify current. All models are equipped with Integrated Circuit (IC) voltage regulators.

A diode on the charge indicator light circuit monitors alternating voltage at the stator. Charge indicator light remains off when monitored voltage and charging voltage are equal.

TROUBLE SHOOTING

CHARGING SYSTEM

TROUBLE SHOOTING NO START CONDITION

Possible Cause	Action
Dead Battery	Check/Replace Battery
Bad Cable Connections	Clean/Replace Cables
Ignition Switch/Circuit Fault	Check Switch/Circuit

TROUBLE SHOOTING CHARGING SYSTEM WARNING LIGHT STAYS ON

Possible Cause	Action
Loose/Worn Alternator Belt	Tighten/Replace Belt
Loose Alternator Connections	Check/Repair Connections
Warning Light Wiring	Check/Repair Wiring
Faulty Stator/Diodes	Test/Repair Alternator
Faulty Voltage Regulator	Test/Repair Regulator

TROUBLE SHOOTING WARNING LIGHT OFF WITH IGNITION SWITCH ON

Possible Cause	Action
Blown Fuse	Check/Replace Fuse
Faulty Alternator	Test Alternator
Bad Warning Light Bulb	Test/Replace Bulb

TROUBLE SHOOTING WARNING LIGHT ON WITH IGNITION SWITCH OFF

Possible Cause	Action
Alternator Wiring Short	Check/Repair Wiring
Faulty Rectifier Bridge	Test/Repair Alternator

TROUBLE SHOOTING AMMETER INDICATES DISCHARGE

Possible Cause	Action
Loose/Worn Alternator Belt	Tighten/Replace Belt
Loose Alternator Connections	Check/Repair Connections
Faulty Ammeter	Test/Replace Ammeter
NOISY Defective Battery	Replace Battery
Defective Alternator	Test/Repair Alternator
Defective Regulator	Test/Repair Regulator

ADJUSTMENTS

BELT TENSION

ALTERNATOR BELT ADJUSTMENT

Application	(1) Deflection - In. (mm)
1990 Axxess	7/32 (6)
1990 Pulsar NX	7/32 (7)
Maxima	5/16 (8)
NX	5/16 (8)
Pathfinder & Pickup (V6)	13/32 (10)
Pickup (4 Cylinder)	3/8 (9)
Sentra	5/16 (8)
Stanza	1/4 (6)
240SX	1/4 (6)
300ZX	9/32 (7)

(1) - Deflection is with 22 lbs. (10 kg) pressure applied midway on the longest belt run.

ON-VEHICLE TESTING

ALTERNATOR TEST

1) Ensure battery is fully charged before starting test. Turn ignition on and check charge indicator light on instrument panel. If light comes on, go to step 3).

NOTE: Terminals "S", "L", "B", and "E" are marked on alternator's rear cover. Terminal "F" is inside alternator.

2) If light is off, disconnect alternator connector and ground wire of terminal "L". If light remains off, replace indicator bulb and recheck. If light comes on, reconnect alternator and ground internal terminal "F" using jumper wire. See Fig. 1. If light is off, repair alternator. If light is on, replace IC regulator.

Jumper Wire

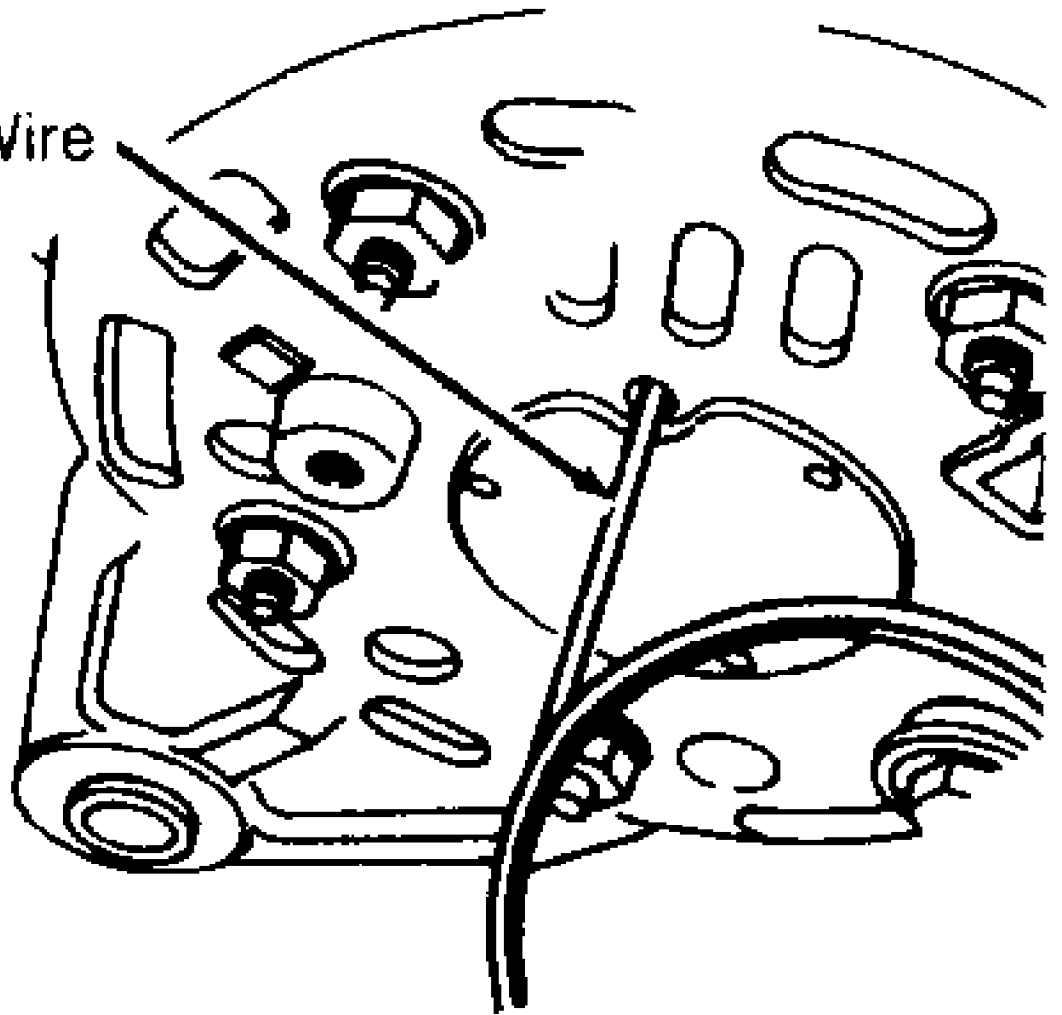

Fig. 1: Full Fielding Hitachi Alternator
Courtesy of Nissan Motor Co., U.S.A.

3) Start and run engine at idle. If light is dim, flickers or remains on (bright), repair alternator. If the light goes off, operate engine at 1500 RPM and turn on headlights. If charge indicator light remains off, go to step 4). If charge indicator light comes on, replace IC regulator.

4) Run engine at 1500 RPM and measure voltage at terminal "B". If voltage is more than 15.5 volts, replace IC regulator. If voltage is 13-15 volts, alternator and regulator are okay.

BENCH TESTING

ROTOR

Connect ohmmeter leads to each of the rotor slip rings. If continuity is present, rotor is okay. If continuity is NOT present, rotor is defective. Connect an ohmmeter lead to any rotor slip ring

and connect remaining lead to rotor core. If continuity exists, replace rotor assembly.

NOTE: To test stator or diodes, separate them by unsoldering the connecting wires. Use just enough heat to melt solder. Excess heat will damage diodes.

STATOR

Using ohmmeter, check continuity between stator core leads. If continuity is NOT present between leads, replace stator. Connect an ohmmeter lead to stator core. Connect remaining ohmmeter lead, in turn, to each of the stator leads. If continuity is NOT present, stator is good. If continuity exists, stator is grounded and must be replaced.

DIODES

Using an ohmmeter, check continuity of all diodes in both directions. Ensure continuity exists in only one direction. See ALTERNATOR DIODES CONTINUITY table. If continuity exists in both directions, diode is shorted. See Fig. 2. If continuity is NOT present in either direction, diode is open. If any diode is defective, replace entire diode assembly.

ALTERNATOR DIODES CONTINUITY

Positive (+) Lead	Negative (-) Lead	Continuity
Diode Plate	Diode Terminals	Yes
Diode Terminals	Diode Plate	No
- Diode Plate	Diode Terminals	No
Diode Terminals	- Diode Plate	Yes

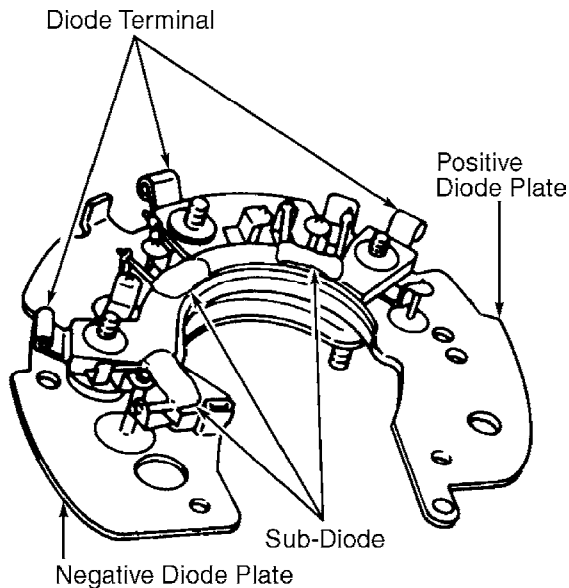

90109387
Fig. 2: Testing Diode Assembly
Courtesy of Nissan Motor Co., U.S.A.

BRUSHES

Inspect brushes for freedom of movement in holder. Clean brush holder if necessary. Check brushes for cracks and wear. Check brush springs for corrosion or damage. Ensure brushes are not worn beyond minimum length. Refer to ALTERNATOR APPLICATIONS table or ALTERNATOR SPECIFICATIONS table.

ALTERNATOR APPLICATIONS

Application	Hitachi Part No.
1990 Axxess	LR180-719
Maxima	LR190-711
Pathfinder & Pickup	
2.4L	LR160-723B
3.0L	LR170-739
NX & Sentra	
1.6L	LR170-738B
2.0L	LR180-725
1990 Pulsar NX	LR165-707
Stanza	LR180-719
240SX	LR180-729
300ZX	LR180-724

ALTERNATOR SPECIFICATIONS

Hitachi Part No.	Output Amp @ RPM	(1) Brush Length In. (mm)
LR180-719	67 @ 5000	.28 (7)
LR190-711	84 @ 5000	.28 (7)
LR160-723B	57 @ 5000	.24 (6)
LR170-739	67 @ 5000	.24 (6)
LR170-738B	67 @ 5000	.24 (6)
LR180-725	77 @ 5000	.24 (6)
LR165-707	62 @ 5000	.24 (6)
LR180-719	67 @ 5000	.24 (7)
LR180-729	77 @ 5000	.24 (6)
LR180-724	80 @ 5000	.28 (7)

(1) - Minimum brush length.

OVERHAUL

NOTE: A ring is used to lock outer bearing race in alternator's rear cover. It may be necessary to heat bearing housing to remove cover. Use a 200-watt soldering iron to heat housing. DO NOT use heat gun as it may damage diode. See Fig. 3 for exploded view of alternator.

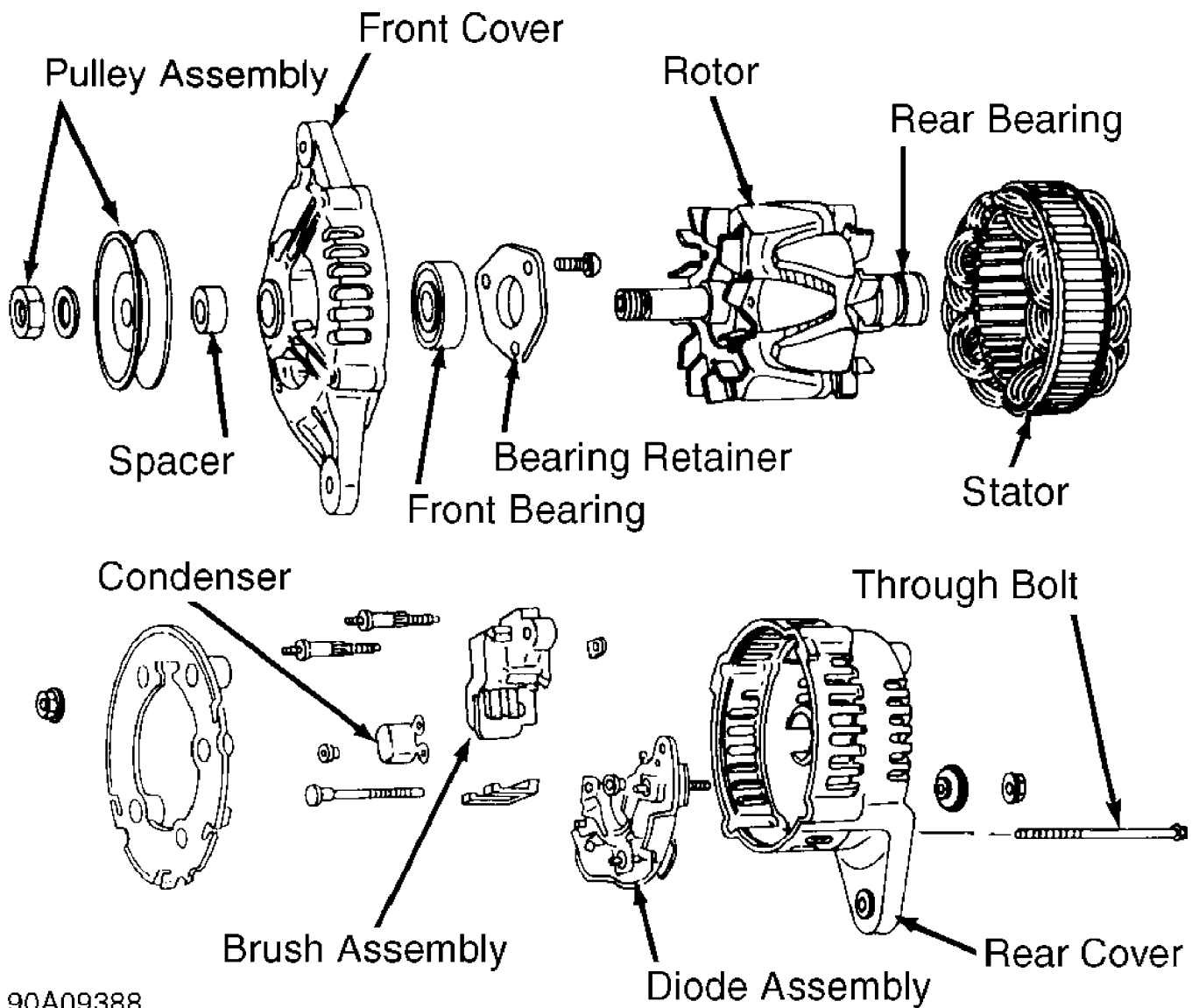

90A09388

Fig. 3: Exploded View of Hitachi Alternator
 Courtesy of Nissan Motor Co., U.S.A.

WIRING DIAGRAMS

See appropriate chassis wiring diagram in WIRING DIAGRAMS.