

ENGINE COOLING FAN

1990 Nissan 240SX

1990 ENGINE COOLING
Nissan Cooling Fans

Axxess, Maxima, Pathfinder, Pickup,
Pulsar NX, Sentra, Stanza, 240SX, 300ZX

FAN TROUBLE SHOOTING & SYSTEM TESTING

AXXESS

NOTE: Pathfinder and Pickup do not use electric cooling fans.

Warm engine to operating temperature. Turn on A/C and fan switch. Both cooling fans should run at low speed. Disconnect coolant temperature sensor connector. Both cooling fans should run at high speed. If not, check power supplies, grounds, relays, radiator fan switches and motors. If no faults are found, check component wiring. See Fig. 2.

MAXIMA

Warm engine to operating temperature. Engage A/C clutch using A/C switch in passenger compartment. Both cooling fans should run at low speed. Disconnect coolant temperature sensor connector. Both cooling fans should run at high speed. If not, check power supplies, grounds, relays, radiator fan switches and motors. If no faults are found, check component wiring. See Fig. 3.

PULSAR, SENTRA

Warm engine to operating temperature. Cooling fan should come on. Engage A/C clutch using A/C switch in passenger compartment. Condenser cooling fan should come on. If not, check power supplies, grounds, relays, radiator fan switches and motors. If no faults are found, check component wiring. See Fig. 4.

STANZA

Start engine. Engage A/C clutch using A/C switch in passenger compartment. Both cooling fans should run at low speed. On models equipped with auto. trans., turn A/C blower motor to "HI". One cooling fan should run faster than the other. On all models, turn A/C off. Warm engine to operating temperature. Both cooling fans should run. On models equipped with auto. trans., if coolant temperature rises to greater than 212°F (100°C), one cooling fan should run faster than the other. If cooling fans do not function as described, check power supplies, grounds, relays, radiator fan switches and motors. If no faults are found, check component wiring. See Fig. 5.

240SX

Warm engine to operating temperature. Engage A/C clutch using A/C switch in passenger compartment. Cooling fan should run. If not, check power supplies, grounds, relay, radiator fan switch and motor. If no faults are found, check component wiring. See Fig. 6.

300ZX

Warm engine to operating temperature. Cooling fan should run. If not, check power supplies, grounds, relays, radiator fan switches and motors. If no faults are found, check component wiring. See Fig. 7.

COMPONENT TESTING

FAN MOTOR TEST

Disconnect electrical connector at fan motor. Supply battery voltage and ground to fan motor connector. Motor should run. If not, check for open or short in motor windings.

RELAYS TEST

1) Three different cooling fan relays are used. They are a 4-wire double contact relay (Blue), a 4-wire toggle select relay (Black) and a 6-wire dual function relay (Brown). See Fig. 1.

2) Test relays by supplying ground and battery voltage across the relay winding of the relay (terminals No. 1 and 2). When relay is energized, continuity should be present between terminals No. 3 and 5, and also terminals No. 6 and 7 of the Brown dual function relay. When de-energized, continuity should exist between terminals No. 4 and 5 of the Black toggling relay. Continuity should exist between terminals No. 1 and 2 of all relays.

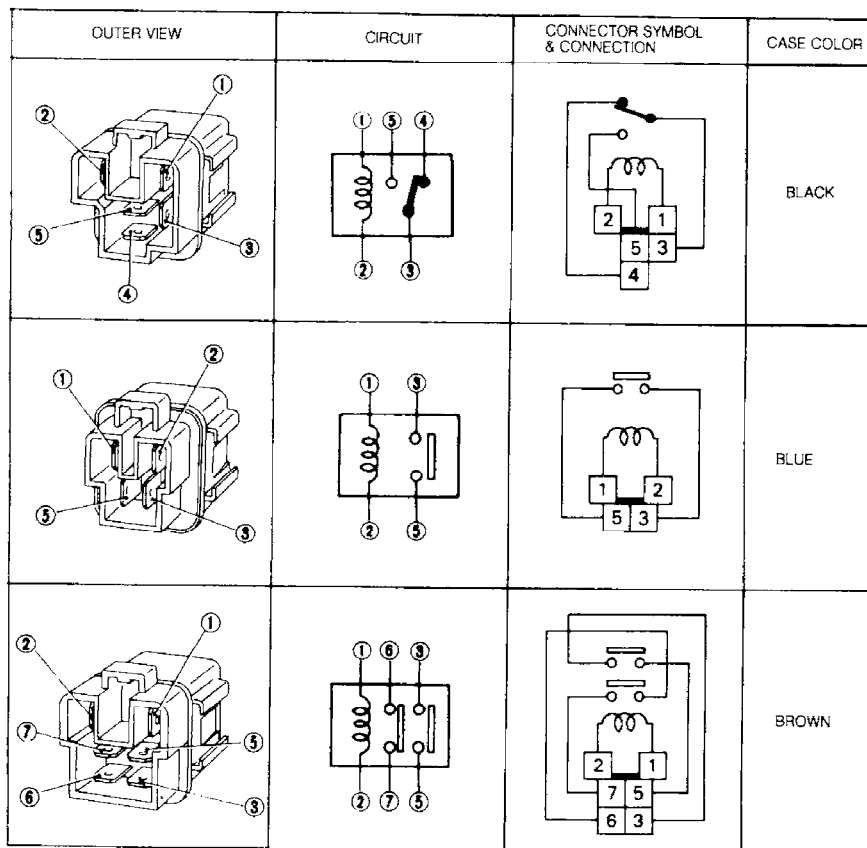

Fig. 1: Identifying Cooling Fan Relay Internals & Test Terminals
 Courtesy of Nissan Motor Co., U.S.A.

RADIATOR FAN SWITCH TEST

1) With coolant temperature less than rated activation temperature, check continuity across terminals of radiator fan switch. See RADIATOR FAN SWITCH TEMPERATURE table. Continuity should not exist. Warm engine to operating temperature. Continuity should now exist.

2) If continuity does not exist, remove radiator fan switch. Check for coating of switch with foreign substance. Bench test switch using a thermometer, a glass or metal container filled with coolant mixture, and a heat source. Check resistance at rated temperature. If switch does not function properly, replace switch.

RADIATOR FAN SWITCH TEMPERATURE TABLE

RADIATOR FAN SWITCH TEMPERATURE TABLE

Application	Activation Temp. °F (°C)
Axxess	(1)
Maxima	(1)
Pulsar NX	180-190 (82-88)
Sentra	180-190 (82-88)
Stanza	(1)
240SX	198-208 (92-98)
300ZX	(1)

(1) - A/C request and coolant temperature sensor input are used by the ECCS engine control unit to regulate cooling fan operation.

WIRING DIAGRAMS

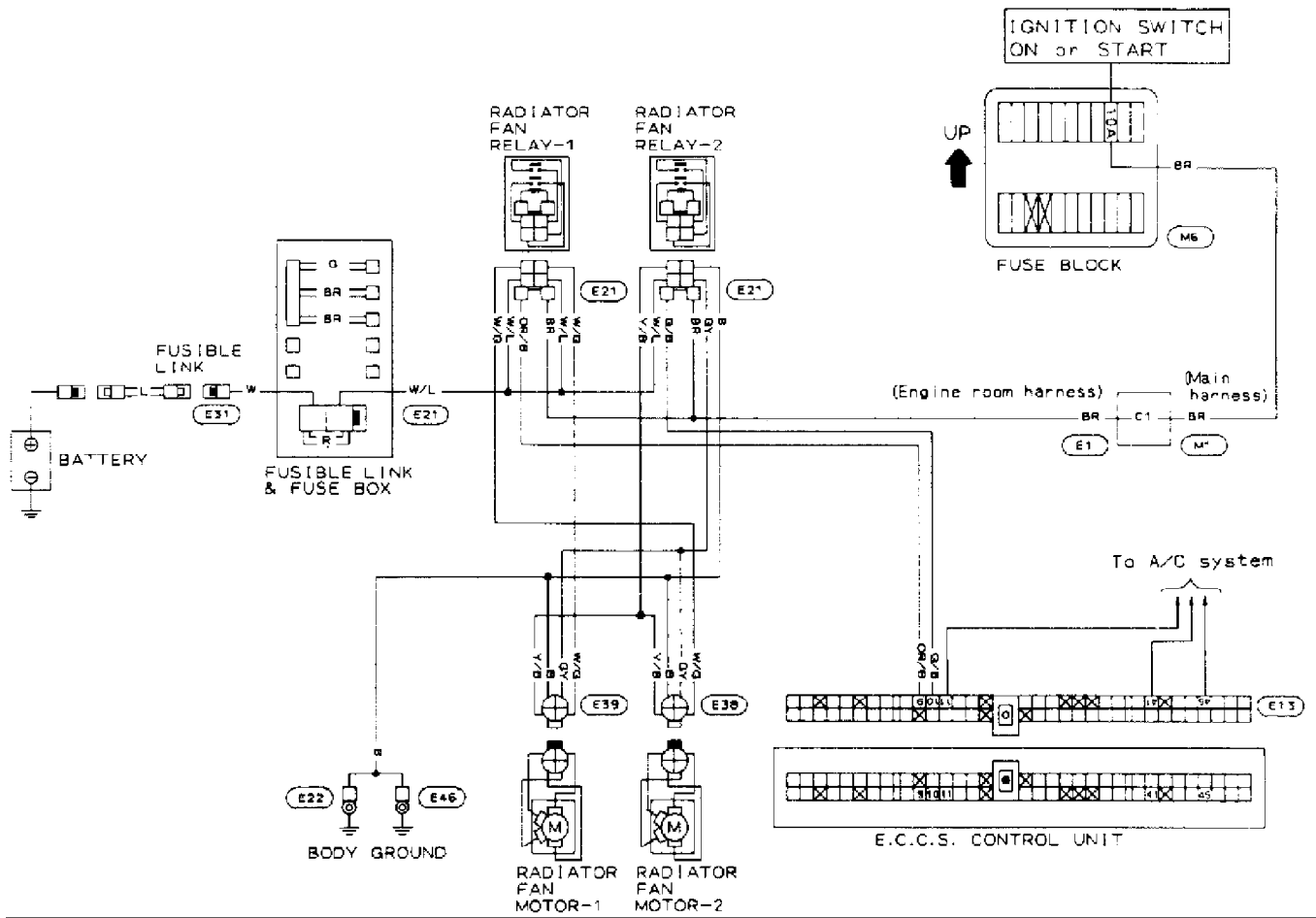
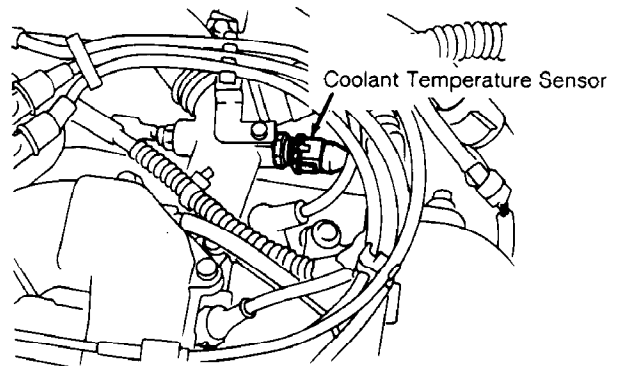
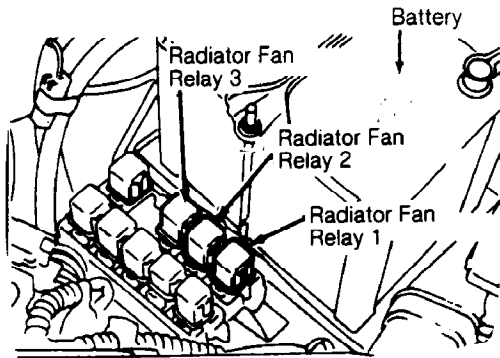
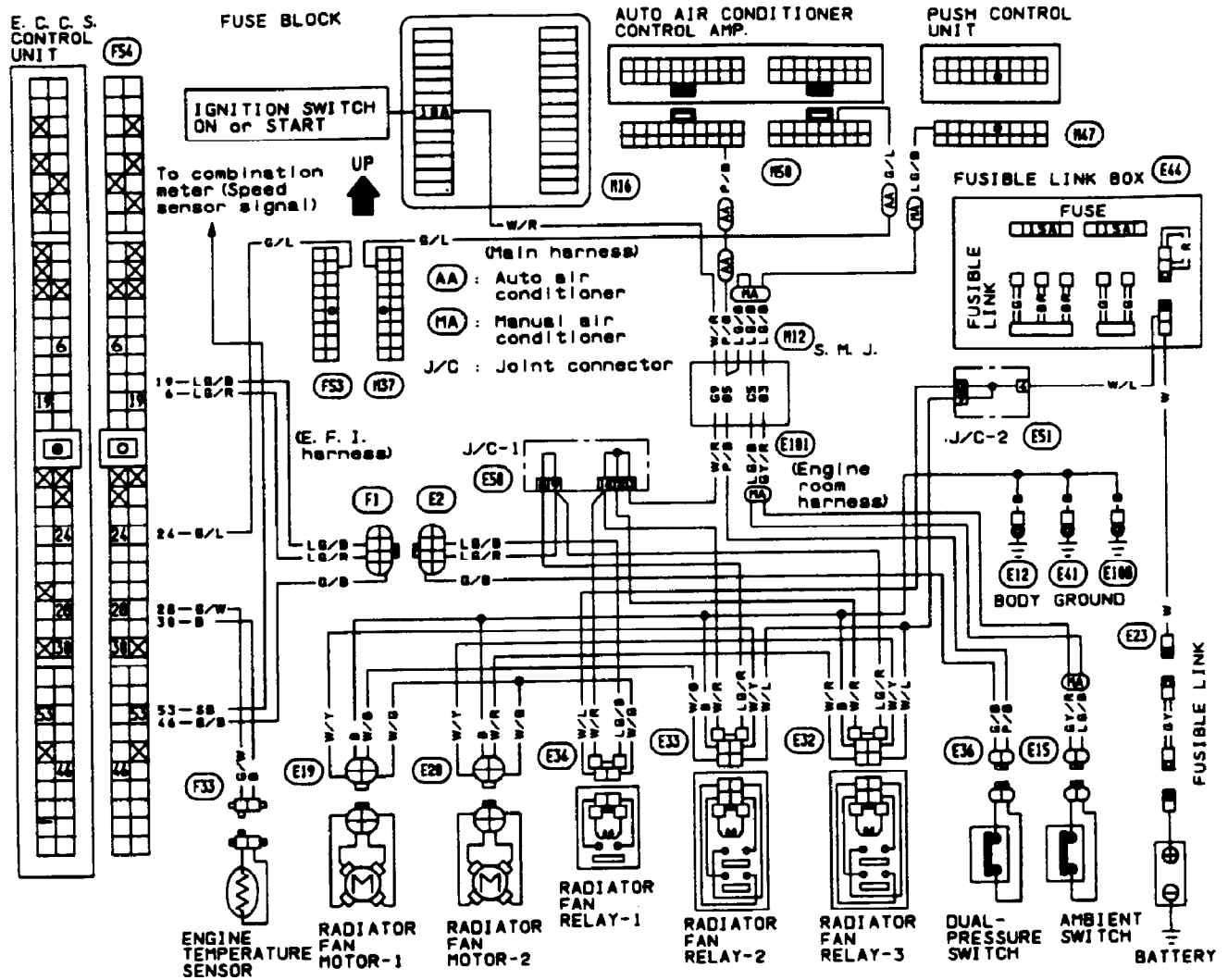

Fig. 2: Axxess Electric Cooling Fan Wiring Schematic



90B09421

Fig. 3: Maxima Electric Cooling Fan Wiring Schematic

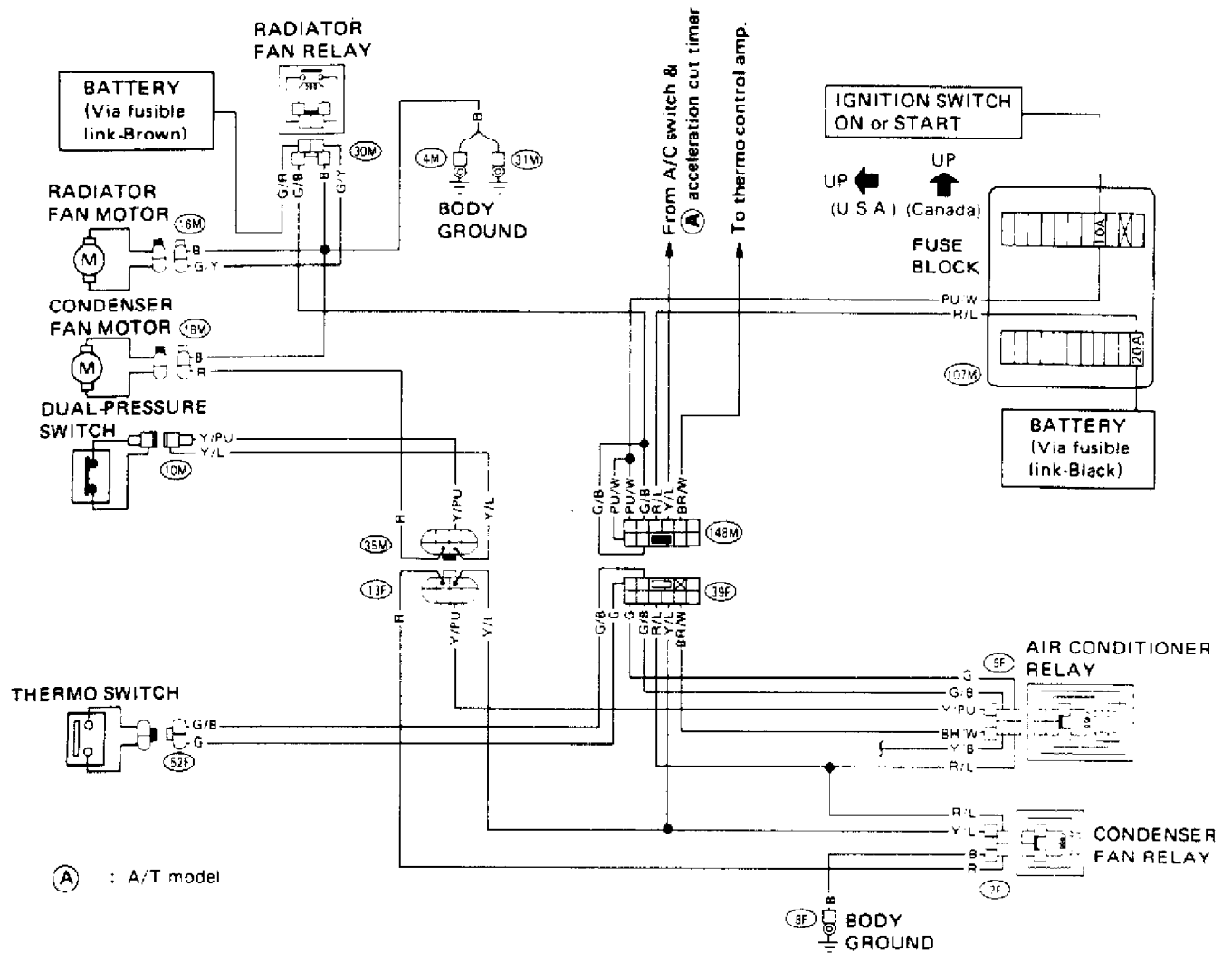
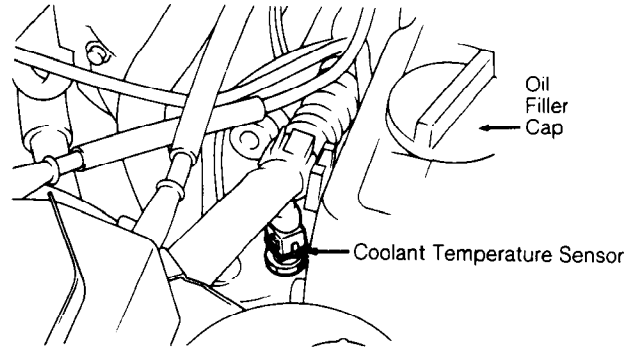
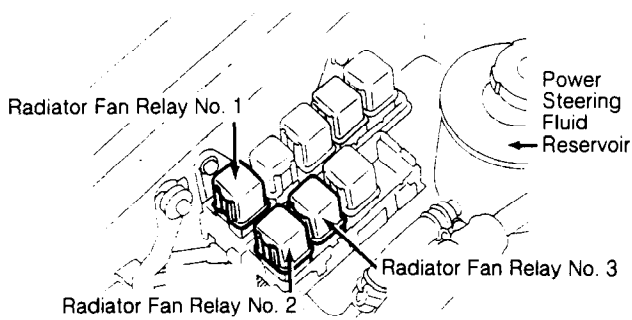
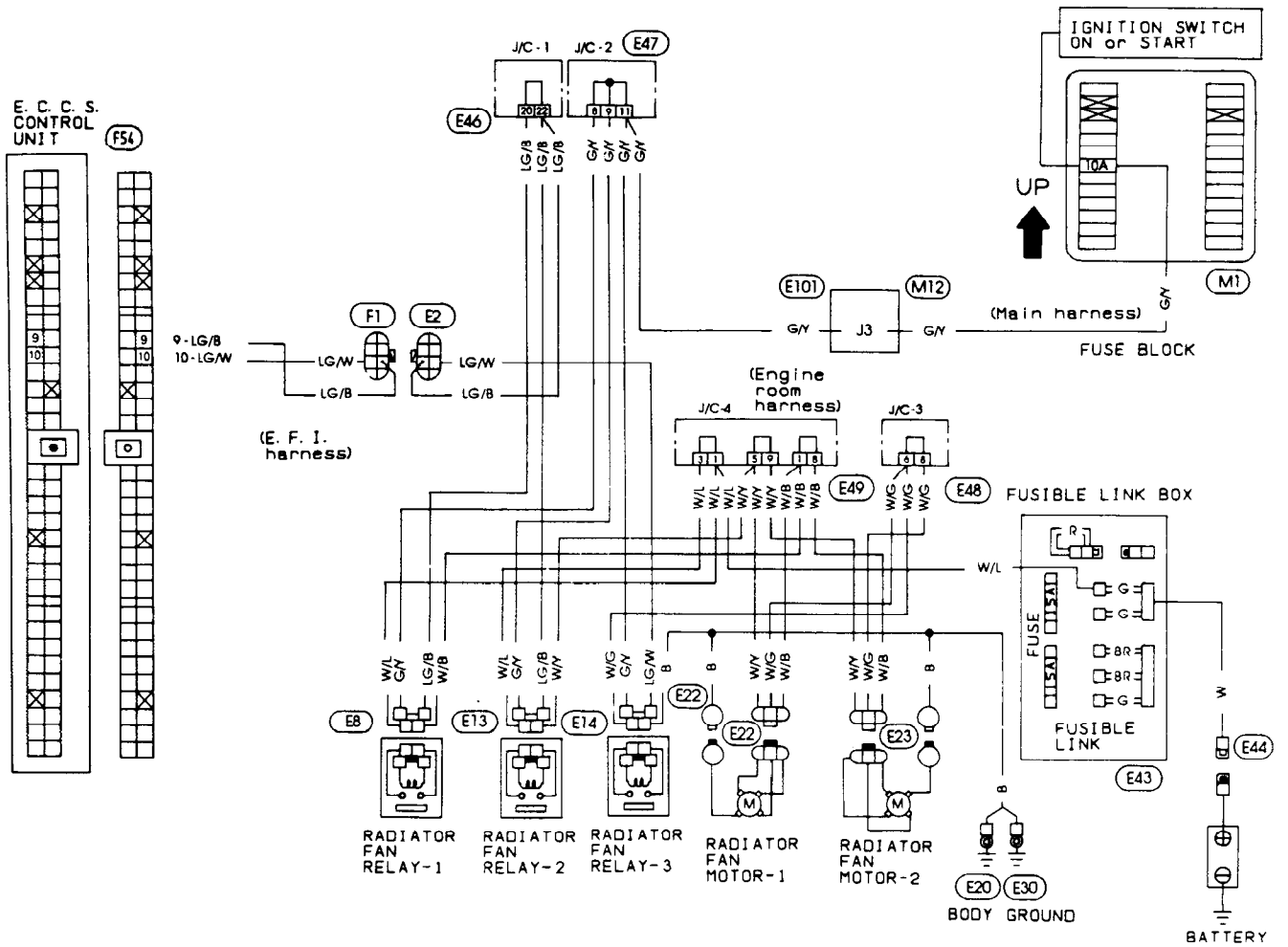

Fig. 4: Pulsar NX & Sentra Electric Cooling Fan Wiring Schematic



91G02361

Fig. 5: Stanza Electric Cooling Fan Wiring Schematic

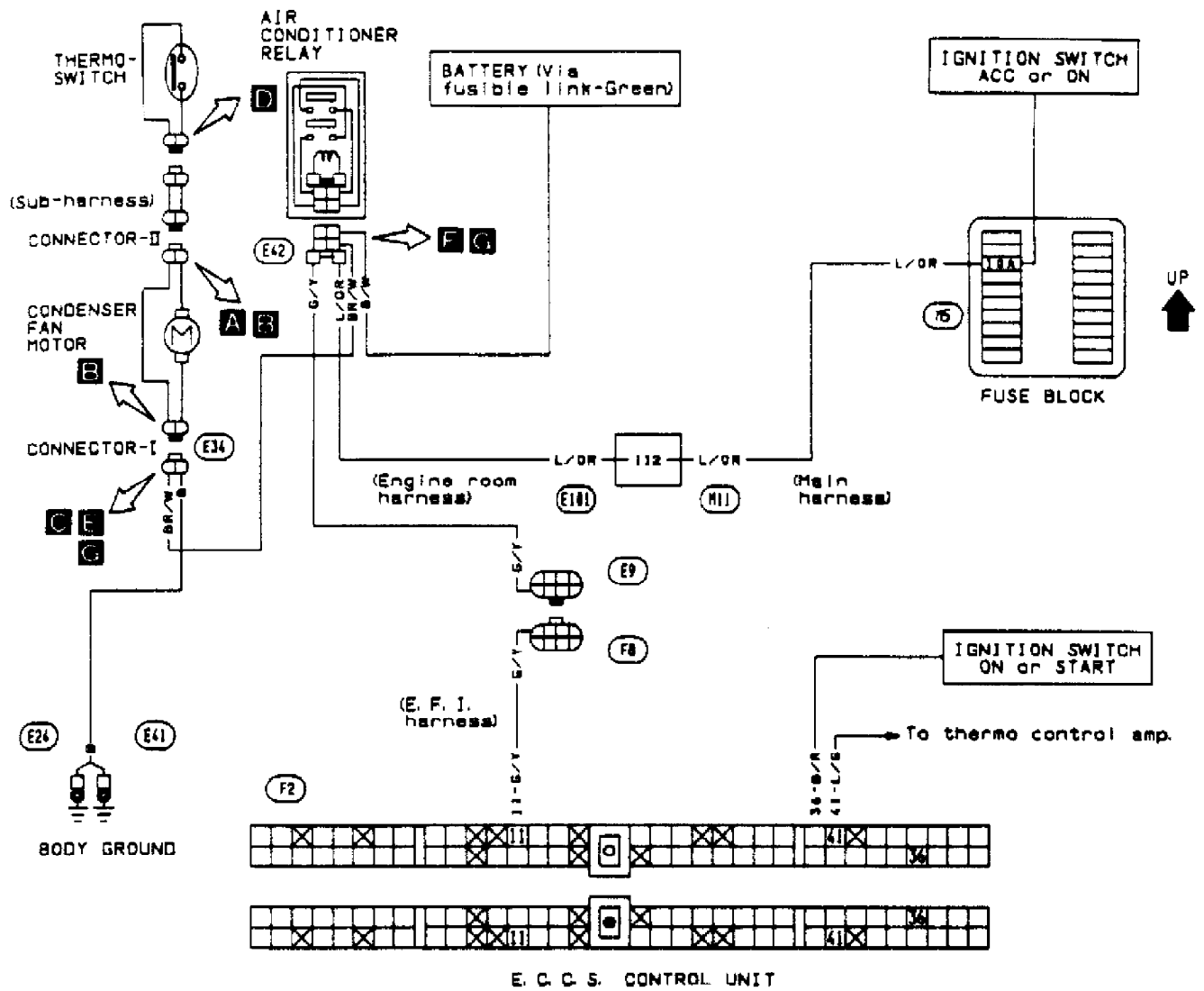

Fig. 6: 240SX Electric Cooling Fan Wiring Schematic

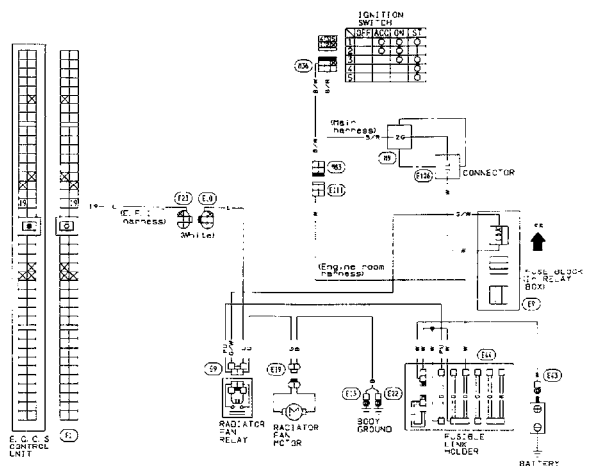

Fig. 7: 300ZX Electric Cooling Fan Wiring Schematic

