

SCHEDULED SERVICES

1990 Nissan 240SX

1989-94 MAINTENANCE
Nissan Maintenance & Service Intervals

240SX
240SX Convertible (1992-94)

* PLEASE READ THIS FIRST *

NOTE: All SERVICE SCHEDULES are listed for normal service vehicles. If vehicle is operated under severe service conditions, see SEVERE SERVICE REQUIREMENTS (PERFORM W/SERVICE SCHEDULES) for items requiring additional maintenance.

NOTE: This article contains scheduled maintenance service information. Fluid types and capacities listed with each service in this article are only those necessary to perform that scheduled service. For specifications pertaining to fluid capacities for the entire vehicle, fuse and circuit breaker identification, wheel and tire size, battery type, warranty information, or model identification refer to the MAINTENANCE INFORMATION article in this section.

CAUTIONS & WARNINGS

SUPPLEMENTAL RESTRAINT SYSTEM (AIR BAG)

NOTE: See the AIR BAGS article in the ACCESSORIES/SAFETY EQUIPMENT Section.

Modifications or improper maintenance, including incorrect removal and installation of the Supplemental Restraint System (SRS), can adversely affect system performance. DO NOT cover, obstruct or change the steering wheel horn pad in any way, as such action could cause improper function of the system. Use only plain water when cleaning the horn pad. Solvents or cleaners could adversely affect the air bag cover and cause improper deployment of the system.

WARNING: To avoid injury from accidental air bag deployment, read and carefully follow all warnings and service precautions. See appropriate AIR BAGS article in ACCESSORIES/SAFETY EQUIPMENT.

CAUTION: Disconnect negative battery cable before servicing any air bag system, steering column or passenger side dash component. After any repair, turn ignition key to the ON position from passenger's side of vehicle in case of accidental air bag inflation

AIR CONDITIONING SERVICING

CAUTION: Avoid breathing R-134a refrigerant and PAG lubricant vapors, exposure may irritate eyes, nose and throat. To remove R-134a from system use R-134a recycling equipment that meets SAE J2210 specifications. If accidental system discharge occurs, ventilate work area before resuming service.

WARNING: R-134a service equipment or vehicle A/C systems SHOULD NOT be pressure tested or leak tested with compressed air. Some

mixtures of air/R134a have shown to be combustible at elevated pressures. These mixtures are dangerous and may cause fire and/or explosions. See AIR CONDITIONING SERVICE article in GENERAL INFORMATION section.

ANTI-LOCK BRAKE SYSTEM

The anti-lock brake system contains electronic equipment that can be susceptible to interference caused by improperly installed or high output radio transmitting equipment. Since this interference could cause the possible loss of the anti-lock braking capability, such equipment should be installed by qualified professionals.

On models equipped with anti-lock brake systems, ALWAYS observe the following cautions:

- * DO NOT attempt to bleed hydraulic system without first referring to the appropriate ANTI-LOCK BRAKE SYSTEM article in the BRAKES Section.
- * DO NOT mix tire sizes. As long as tires remain close to the original diameter, increasing the width is acceptable. Rolling diameter must be identical for all 4 tires. Some manufacturers recommend tires of the same brand, style and type. Failure to follow this precaution may cause inaccurate wheel speed readings.
- * Use ONLY recommended brake fluids. DO NOT use silicone brake fluids in an ABS-equipped vehicle.

BATTERY WARNING

WARNING: When battery is disconnected, vehicles equipped with computers may lose memory data. When battery power is restored, driveability problems may exist on some vehicles. These vehicles may require a relearn procedure. See COMPUTER RELEARN PROCEDURES article in GENERAL INFORMATION section.

REPLACING BLOWN FUSES

Before replacing a blown fuse, remove ignition key, turn off all lights and accessories to avoid damaging the electrical system. Be sure to use fuse with the correct indicated amperage rating. The use of an incorrect amperage rating fuse may result in a dangerous electrical system overload.

BRAKE PAD WEAR

Disc brake pads have audible wear warnings. When a brake pad requires replacement, it will make a high pitched scraping sound when vehicle is in motion whether or not brake pedal is depressed. Have brakes checked as soon as possible if warning sound is heard.

CATALYTIC CONVERTER

Continued operation of vehicle with a severe malfunction could cause converter to overheat, resulting in possible damage to converter and vehicle.

Any modification to the exhaust system on turbo models, which reduces exhaust backpressure, will lead to lean fuel mixtures and excessive spark advance. This could cause serious engine damage.

ELECTROSTATIC DISCHARGE SENSITIVE (ESD) PARTS

WARNING: Many solid state electrical components can be damaged by static electricity (ESD). Some will display a warning label, but many will not. Discharge personal static electricity by touching a metal ground point on the vehicle prior to servicing any ESD sensitive component.

ENGINE OIL

CAUTION: Never use non-detergent or straight mineral oil.

FUEL INJECTION LINES

On vehicles equipped with electronic fuel injection, the fuel filter and fuel lines are under high pressure even when the engine is off.

FUEL SYSTEM SERVICE

WARNING: Relieve fuel system pressure prior to servicing any fuel system component (fuel injection models).

HALOGEN BULBS

Halogen bulbs contain pressurized gas which may explode if overheated. DO NOT touch glass portion of bulb with bare hands. Eye protection should be worn when handling or working around halogen bulbs.

RADIATOR CAP

CAUTION: Always disconnect the fan motor when working near the radiator fan. The fan is temperature controlled and could start at any time even when the ignition key is in the OFF position. DO NOT loosen or remove radiator cap when cooling system is hot.

RADIATOR FAN

WARNING: Keep hands away from radiator fan. Fan is controlled by a thermostatic switch which may come on or run for up to 15 minutes even after engine is turned off.

SPARE TIRE USAGE

Ensure correct lug nuts are used when the spare tire is fitted. DO NOT use lug nuts from alloy wheels on steel wheels.

VEHICLE LOADING

The vehicle weight capacity is indicated on the FMVSS certification label found on the trailing edge of the driver's side door. DO NOT load the vehicle beyond the listed capacity.

SERVICE POINT LOCATIONS

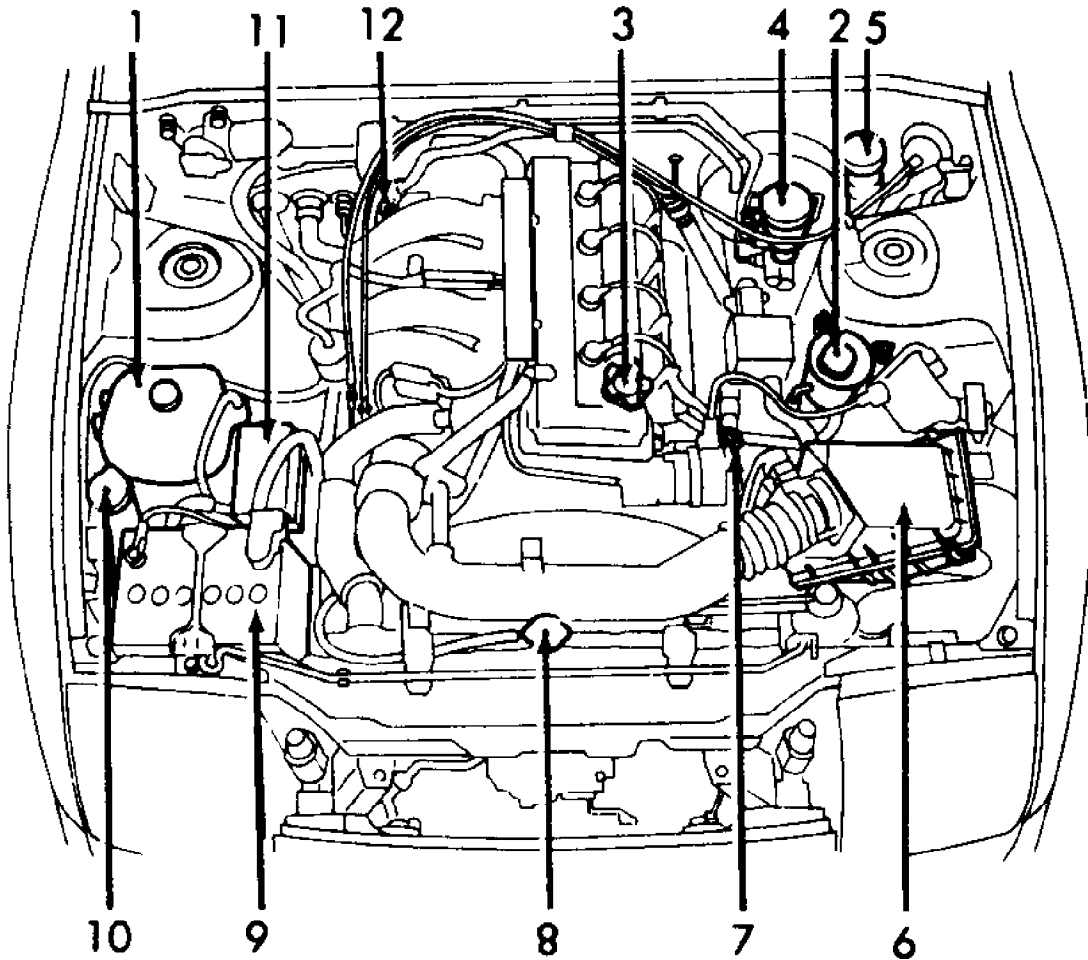

1. Coolant Recovery Reservoir
2. Power Steering Fluid Reservoir
3. Engine Oil Filler Cap
4. Brake Fluid Reservoir
5. Clutch Fluid Reservoir
6. Air Cleaner
7. Engine Oil Dipstick
8. Radiator Cap
9. Battery
10. Washer Fluid Reservoir
11. Fuse Box
12. Automatic Transmission Fluid Dipstick

90C04966

Fig. 1: Engine Service Point Locations
 Courtesy of Nissan Motor Co., U.S.A.

SEVERE & NORMAL SERVICE DEFINITIONS

NOTE: Use the Severe Service schedule if the vehicle to be serviced is operated under ANY (one or more) of these conditions:

Service is recommended at mileage intervals based on vehicle operation. Service schedules are based on the following primary operating conditions:

Normal Service

- * Driven More Than 10 Miles Daily
- * No Operating Conditions From Severe Service Schedule

Severe Service (Unique Driving Conditions)

- * Repeated Short Distance Driving
- * Extensive Idling
- * Driving In Dusty Conditions
- * Driving On Rough, Muddy, Or Salt Spread Roads
- * Towing A Trailer

SEVERE SERVICE REQUIREMENTS (PERFORM W/SERVICE SCHEDULES)

NOTE: The following services are to be performed on vehicles subjected to severe service. See SEVERE & NORMAL SERVICE DEFINITIONS. This service is to be performed in addition to the normal services listed in the NORMAL MAINTENANCE SERVICE SCHEDULES.

SEVERE SERVICE CONDITIONS/ACTIONS TABLE

Condition	Action	Item	Perform Every (1)
Repeated Short Distance Driving	Replace	Engine Oil & Filter	3,000 Miles or 3 Months
	Inspect	Transmission Fluid	15,000 Miles or 12 Months
	Inspect	Differential Oil	15,000 Miles or 12 Months
	Replace	Transmission Fluid	30,000 Miles or 24 Months
	Replace	Differential Oil	30,000 Miles or 24 Months
Extensive Idling	Replace	Engine Oil & Filter	3,000 Miles or 3 Months
	Inspect	Transmission Fluid	15,000 Miles or 12 Months
	Inspect	Differential Oil	15,000 Miles or 12 Months
	Replace	Transmission Fluid	30,000 Miles or 24 Months
	Replace	Differential Oil	30,000 Miles or 24 Months

Driving In Dusty Conditions	Replace	Engine Oil & Filter	3,000 Miles or 3 Months
	Inspect	Transmission Fluid	15,000 Miles or 12 Months
	Inspect	Differential Oil	15,000 Miles or 12 Months
	Replace	Transmission Fluid	30,000 Miles or 24 Months
	Replace	Differential Oil	30,000 Miles or 24 Months
Driving On Rough, Muddy, Or Salt Spread Roads	Replace	Engine Oil & Filter	3,000 Miles or 3 Months
	Inspect	Transmission Fluid	15,000 Miles or 12 Months
	Inspect	Differential Oil	15,000 Miles or 12 Months
	Replace	Transmission Fluid	30,000 Miles or 24 Months
	Replace	Differential Oil	30,000 Miles or 24 Months
Towing A Trailer	Replace	Engine Oil & Filter	3,000 Miles or 3 Months
	Inspect	Transmission Fluid	15,000 Miles or 12 Months
	Inspect	Differential Oil	15,000 Miles or 12 Months
	Replace	Transmission Fluid	30,000 Miles or 24 Months
	Replace	Differential Oil	30,000 Miles or 24 Months
(1) - Perform these services at the mileage or number of months (since the last time), whichever comes first.			

NORMAL MAINTENANCE SERVICE SCHEDULES

The following service schedules refer to vehicles driven under normal operating conditions. For vehicles driven under severe conditions, additional services may be necessary. See SEVERE SERVICE REQUIREMENTS (PERFORM W/SERVICE SCHEDULES) above in this article for additional service requirements.

7500 MILE (12,000 KM) SERVICE

7500 MILE (12,000 KM) SERVICE

Service Or Inspect	
	Check Fluid Levels
	Inspect Coolant Hoses and Clamps
	Inspect Brake System
	Inspect Exhaust System
	Inspect C/V Joint boots
	Inspect Steering Linkage/Front Suspension
	Lubricate Chassis
	Rotate Tires and Adjust Air Pressure (Including Spare)
Replace	
	Engine Oil
	Oil Filter
Lubrication Specifications	
Application	Specification
Engine Oil	
Preferred For All Ambient Temperatures	
	SAE 5W-30 API SG
Minimum Temperature	
Greater Than 32°F (0°C)	SAE 10W-30 Or 10W-40 API SG
Greater Than 50°F (10°C)	SAE 20W-40 Or 20W-50 API SG
Fluid Capacities	
Application	(1) Quantity
Engine Oil (2)	3.7-4.0 Qts. (3.5-3.8L)
(1) - Capacities are recommended or calculated levels. Always use dipstick (if available) to measure level.	
(2) - Includes filter change.	

15,000 MILE (24,000 KM) SERVICE

15,000 MILE (24,000 KM) SERVICE

Service Or Inspect	
	Verify Last Major Service Was Performed
	Check Fluid Levels
	Check Cooling System Hoses and Clamps
	Check Coolant Strength
	Inspect Brake System

Check Exhaust System & Heat Shielding
Clean Battery and Battery Terminals
Inspect Fuel/Tank/Cap/Lines
Check Operation of Horn, Wipers/Washers & All Exterior Lights
Inspect Condition of Wiper Blades
Check Headlight Alignment
Check Seat Belt Webbing and Release Mechanisms
Check Parking Brake Operation
Check Shift/Clutch Interlock Operation
Inspect C/V Joint boots
Brake Discs & Calipers
Parking Brake
Inspect Steering Linkage/Front Suspension
Lubricate Chassis
Suspension Mounting Bolts
Power Steering System
Lubricate Weatherstripping with Silicone
Lubricate Door Hinges
Lubricate Door Locks
Check Body Drain Holes
Rotate Tires and Adjust Air Pressure
Replace
Engine Oil
Oil Filter

Lubrication Specifications

Application	Specification
Differential Gear Oil	
Maximum Temperature Less Than 104°F (40°C)	SAE 80W-90 API GL-5
Minimum Temperature Greater Than 104°F (40°C)	SAE 140 API GL-5
Engine Oil	
Preferred For All Ambient Temperatures	SAE 5W-30 API SG
Minimum Temperature Greater Than 32°F (0°C)	SAE 10W-30 Or 10W-40 API SG

Greater Than 50°F (10°C)	SAE 20W-40 Or 20W-50 API SG
Transmission	
Automatic Transmission	Nissan ATF Or Dexron-II ATF
Manual Transmission	
Maximum Temperature	
Less Than 104°F (40°C)	SAE 80W-90 API GL-4
Minimum Temperature	
Greater Than 104°F (40°C)	SAE 140 API GL-4

Fluid Capacities

Application	(1) Quantity
Automatic Transmission Fluid	8.8 Qts. (8.3L)
Differential	
R200	1.4 Qts. (1.3L)
R200V	1.6 Qts. (1.5L)
Engine Oil (2)	3.7-4.0 Qts. (3.5-3.8L)
Manual Transmission Oil	2.5 Qts. (2.4L)
(1) - Capacities are recommended or calculated levels. Always use dipstick (if available) to measure level.	
(2) - Includes filter change.	

Service Labor Times

Application	Hours
2.4L	1.5

22,500 MILE (36,000 KM) SERVICE

22,500 MILE (36,000 KM) SERVICE

Service Or Inspect
Verify Last Major Service Was Performed
Check Fluid Levels
Check Cooling System Hoses and Clamps
Check Exhaust System & Heat Shielding
Inspect C/V Joint boots
Inspect Power Steering System (If Equipped)
Inspect Steering Linkage/Front Suspension
Lubricate Chassis
Inspect Front Brake Pads & Rotors
Inspect Rear Brake Linings & Drums
Inspect Brake System Hoses & Lines
Inspect Shocks/Struts for Leakage
Inspect Tire Wear Pattern

Rotate Tires and Adjust Air Pressure (Including Spare)	
Replace	
Engine Oil	
Oil Filter	
Lubrication Specifications	
Application	Specification
Engine Oil	
Preferred For All	
Ambient Temperatures	SAE 5W-30 API SG
Minimum Temperature	
Greater Than 32°F (0°C)	SAE 10W-30 Or 10W-40 API SG
Greater Than 50°F (10°C)	SAE 20W-40 Or 20W-50 API SG
Fluid Capacities	
Application	(1) Quantity
Engine Oil (2)	3.7-4.0 Qts. (3.5-3.8L)
(1) - Capacities are recommended or calculated levels. Always use dipstick (if available) to measure level.	
(2) - Includes filter change.	

30,000 MILE (48,000 KM) SERVICE

30,000 MILE (48,000 KM) SERVICE

Service Or Inspect	
Verify Last Major Service Was Performed	
Check Fluid Levels	
Check Cooling System Hoses and Clamps	
Check Exhaust System & Heat Shielding	
Clean Battery and Battery Terminals	
Inspect/Adjust Accessory Drive Belts (Replace if Required)	
Vapor Lines	
Fuel Lines	
Steering Gear & Linkage	
Super HICAS Linkage (If Equipped)	
Crankcase Ventilation System	
ABS System Operation	
Brake Hoses & Lines	

Brake Discs & Calipers	
Rear Brake Drums, Wheel Cylinders & Linings	
Parking Brake	
Suspension Mounting Bolts	
Steering Operation, Tie Rods, Gear Box & Boots	
Inspect C/V Joint boots	
Inspect Power Steering System (If Equipped)	
Suspension Bushings, Springs, Arms & Rear Jounce Bumpers	
Parking Brake System	
Inspect Shocks/Struts for Leakage	
Inspect Tire Wear Pattern	
Rotate Tires and Adjust Air Pressure (Including Spare)	
Replace	
Engine Oil	
Oil Filter	
Air Filter Element	
Spark Plugs	
Drain, Flush and Refill Engine Coolant	
Lubrication Specifications	
Application	Specification
Differential Gear Oil	
Maximum Temperature	
Less Than 104°F (40°C)	SAE 80W-90 API GL-5
Minimum Temperature	
Greater Than 104°F (40°C)	SAE 140 API GL-5
Engine Oil	
Preferred For All	
Ambient Temperatures	SAE 5W-30 API SG
Minimum Temperature	
Greater Than 32°F (0°C)	SAE 10W-30 Or 10W-40 API SG
Greater Than 50°F (10°C)	SAE 20W-40 Or 20W-50 API SG
Transmission	
Automatic Transmission	Nissan ATF Or Dexron-II ATF
Manual Transmission	
Maximum Temperature	
Less Than 104°F (40°C)	SAE 80W-90 API GL-4
Minimum Temperature	
Greater Than 104°F (40°C)	SAE 140 API GL-4
Fluid Capacities	
Application	(1) Quantity

Automatic Transmission Fluid	8.8 Qts. (8.3L)
Cooling System	6.3-7.1 Qts. (6.0-6.7L)
Differential	
R200	1.4 Qts. (1.3L)
R200V	1.6 Qts. (1.5L)
Engine Oil (2)	3.7-4.0 Qts. (3.5-3.8L)
Manual Transmission Oil	2.5 Qts. (2.4L)

- (1) - Capacities are recommended or calculated levels. Always use dipstick (if available) to measure level.
(2) - Includes filter change.

Service Labor Times

Application	Hours
2.4L	2.3

37,500 MILE (60,000 KM) SERVICE

37,500 MILE (60,000 KM) SERVICE

Service Or Inspect	
	Verify Last Major Service Was Performed
	Check Fluid Levels
	Check Cooling System Hoses and Clamps
	Check Exhaust System & Heat Shielding
	Inspect Brake System
	Inspect C/V Joint boots
	Inspect Steering Linkage/Front Suspension
	Lubricate Chassis
	Rotate Tires and Adjust Air Pressure (Including Spare)
Replace	
	Engine Oil
	Oil Filter
Lubrication Specifications	
Application	Specification
Engine Oil	
Preferred For All	
Ambient Temperatures	SAE 5W-30 API SG
Minimum Temperature	
Greater Than 32°F (0°C)	SAE 10W-30 Or 10W-40 API SG
Greater Than 50°F (10°C)	SAE 20W-40 Or 20W-50 API SG
Fluid Capacities	

Application	(1) Quantity
Engine Oil (2)	3.7-4.0 Qts. (3.5-3.8L)
(1) - Capacities are recommended or calculated levels. Always use dipstick (if available) to measure level.	
(2) - Includes filter change.	

45,000 MILE (72,000 KM) SERVICE

45,000 MILE (72,000 KM) SERVICE

Service Or Inspect
Verify Last Major Service Was Performed
Check Fluid Levels
Check Cooling System Hoses and Clamps
Check Coolant Strength
Clean Battery and Battery Terminals
Check Exhaust System & Heat Shielding
Check Operation of Horn, Wipers/Washers & All Exterior Lights
Inspect Condition of Wiper Blades
Check Headlight Alignment
Check Seat Belt Webbing and Release Mechanisms
Check Parking Brake Operation
Check Shift/Clutch Interlock Operation
Suspension Mounting Bolts
Inspect C/V Joint boots
Inspect Power Steering System (If Equipped)
Inspect Steering Linkage/Front Suspension
Lubricate Chassis
Inspect Front Brake Pads & Rotors
Inspect Rear Brake Linings & Drums
Inspect Brake System Hoses & Lines
Inspect Fuel Tank/Cap/Lines
Inspect Shocks/Struts for Leakage
Inspect Tire Wear Pattern

Lubricate Weatherstripping with Silicone	
Lubricate Door Hinges	
Lubricate Door Locks	
Check Body Drain Holes	
Rotate Tires and Adjust Air Pressure	
Replace	
Engine Oil	
Oil Filter	
Lubrication Specifications	
Application	Specification
Differential Gear Oil	
Maximum Temperature	
Less Than 104°F (40°C)	SAE 80W-90 API GL-5
Minimum Temperature	
Greater Than 104°F (40°C)	SAE 140 API GL-5
Engine Oil	
Preferred For All	
Ambient Temperatures	SAE 5W-30 API SG
Minimum Temperature	
Greater Than 32°F (0°C)	SAE 10W-30 Or 10W-40 API SG
Greater Than 50°F (10°C)	SAE 20W-40 Or 20W-50 API SG
Transmission	
Automatic Transmission	Nissan ATF Or Dexron-II ATF
Manual Transmission	
Maximum Temperature	
Less Than 104°F (40°C)	SAE 80W-90 API GL-4
Minimum Temperature	
Greater Than 104°F (40°C)	SAE 140 API GL-4
Fluid Capacities	
Application	(1) Quantity
Automatic Transmission Fluid	8.8 Qts. (8.3L)
Differential	
R200	1.4 Qts. (1.3L)
R200V	1.6 Qts. (1.5L)
Engine Oil (2)	3.7-4.0 Qts. (3.5-3.8L)
Manual Transmission Oil	2.5 Qts. (2.4L)
(1) - Capacities are recommended or calculated levels. Always use dipstick (if available) to measure level.	
(2) - Includes filter change.	

52,500 MILE (84,000 KM) SERVICE

52,500 MILE (84,000 KM) SERVICE

Service Or Inspect
Verify Last Major Service Was Performed

Check Fluid Levels	
Check Cooling System Hoses and Clamps	
Check Exhaust System & Heat Shielding	
Inspect Brake System	
Lubricate Chassis	
Inspect C/V Joint boots	
Inspect Steering Linkage/Front Suspension	
Rotate Tires and Adjust Air Pressure (Including Spare)	
Replace	
Engine Oil	
Oil Filter	
Lubrication Specifications	
Application	Specification
Engine Oil	
Preferred For All Ambient Temperatures	SAE 5W-30 API SG
Minimum Temperature	
Greater Than 32°F (0°C)	SAE 10W-30 Or 10W-40 API SG
Greater Than 50°F (10°C)	SAE 20W-40 Or 20W-50 API SG
Fluid Capacities	
Application	(1) Quantity
Engine Oil (2)	3.7-4.0 Qts. (3.5-3.8L)
(1) - Capacities are recommended or calculated levels. Always use dipstick (if available) to measure level.	
(2) - Includes filter change.	

60,000 MILE (96,000 KM) SERVICE

60,000 MILE (96,000 KM) SERVICE

Service Or Inspect
Verify Last Major Service Was Performed
Check Idle Speed (1.6L)
Check Valve Clearance (1.6L)
Check Fluid Levels
Check Cooling System Hoses and Clamps
Check Exhaust System & Heat Shielding

	Clean Battery and Battery Terminals
	Inspect/Adjust Accessory Drive Belts (Replace if Required)
	Evaporative Emission Control System
	Vapor Lines
	Distributor Cap & Rotor
	Ignition Wiring
	Inspect Underhood Wiring Harnesses and Connections
	Inspect Emission Control Vacuum Hoses and Connections
	Inspect Fuel/Tank/Cap/Lines
	Inspect C/V Joint boots
	Inspect Power Steering System (If Equipped)
	Super HICAS Linkage (If Equipped)
	Suspension Bushings, Springs, Arms & Rear Jounce Bumpers
	Lubricate Chassis
	Inspect Brake System
	Parking Brake System
	ABS System Operation
	Brake Hoses & Lines
	Brake Discs & Calipers
	Rear Brake Drums, Wheel Cylinders & Linings
	Suspension Mounting Bolts
	Steering Operation, Tie Rods, Gear Box & Boots
	Inspect Shocks/Struts for Leakage
	Inspect Tire Wear Pattern
	Rotate Tires and Adjust Air Pressure (Including Spare)
	Replace
	Engine Oil
	Oil Filter
	Spark Plugs
	Air Filter Element
	Drain, Flush and Refill Engine Coolant

Lubrication Specifications

Application	Specification
Differential Gear Oil	
Maximum Temperature Less Than 104°F (40°C)	SAE 80W-90 API GL-5
Minimum Temperature Greater Than 104°F (40°C)	SAE 140 API GL-5
Engine Oil	
Preferred For All Ambient Temperatures	
Minimum Temperature Greater Than 32°F (0°C)	SAE 5W-30 API SG
Greater Than 50°F (10°C)	SAE 10W-30 Or 10W-40 API SG
Greater Than 50°F (10°C)	SAE 20W-40 Or 20W-50 API SG
Transmission	
Automatic Transmission	Nissan ATF Or Dexron-II ATF
Manual Transmission	
Maximum Temperature Less Than 104°F (40°C)	SAE 80W-90 API GL-4
Minimum Temperature Greater Than 104°F (40°C)	SAE 140 API GL-4
Fluid Capacities	
Application	(1) Quantity
Automatic Transmission Fluid	8.8 Qts. (8.3L)
Cooling System	6.3-7.1 Qts. (6.0-6.7L)
Differential	
R200	1.4 Qts. (1.3L)
R200V	1.6 Qts. (1.5L)
Engine Oil (2)	3.7-4.0 Qts. (3.5-3.8L)
Manual Transmission Oil	2.5 Qts. (2.4L)
(1) - Capacities are recommended or calculated levels. Always use dipstick (if available) to measure level.	
(2) - Includes filter change.	
Service Labor Times	
Application	Hours
2.4L	2.3

67,500 MILE (108,000 KM) SERVICE

67,500 MILE (108,000 KM) SERVICE

Service Or Inspect
Verify Last Major Service Was Performed
Check Fluid Levels
Check Cooling System Hoses and Clamps
Check Exhaust System & Heat Shielding
Lubricate Chassis

Inspect C/V Joint boots	
Inspect Steering Linkage/Front Suspension	
Inspect Front Brake Pads & Rotors	
Inspect Rear Brake Linings & Drums	
Inspect Brake System Hoses & Lines	
Rotate Tires and Adjust Air Pressure (Including Spare)	
Replace	
Engine Oil	
Oil Filter	
Lubrication Specifications	
Application	Specification
Engine Oil	
Preferred For All	
Ambient Temperatures	SAE 5W-30 API SG
Minimum Temperature	
Greater Than 32°F (0°C)	SAE 10W-30 Or 10W-40 API SG
Greater Than 50°F (10°C)	SAE 20W-40 Or 20W-50 API SG
Fluid Capacities	
Application	(1) Quantity
Engine Oil (2)	3.7-4.0 Qts. (3.5-3.8L)
(1) - Capacities are recommended or calculated levels. Always use dipstick (if available) to measure level.	
(2) - Includes filter change.	

75,000 MILE (120,000 KM) SERVICE

75,000 MILE (120,000 KM) SERVICE

Service Or Inspect
Verify Last Major Service Was Performed
Check Fluid Levels
Check Cooling System Hoses and Clamps
Check Coolant Strength
Check Exhaust System & Heat Shielding
Clean Battery and Battery Terminals
Inspect Brake System
Check Operation of Horn, Wipers/Washers & All Exterior Lights

Inspect Condition of Wiper Blades
Check Headlight Alignment
Check Seat Belt Webbing and Release Mechanisms
Check Parking Brake Operation
Check Shift/Clutch Interlock Operation
Adjust Drive Belt Tension
Lubricate Chassis
Inspect C/V Joint boots
Inspect Power Steering System (If Equipped)
Brake Discs & Calipers
Parking Brake
Suspension Mounting Bolts
Steering Operation, Tie Rods, Gear Box & Boots
Lubricate Weatherstripping with Silicone
Lubricate Door Hinges
Lubricate Door Locks
Check Body Drain Holes
Inspect Shocks/Struts for Leakage
Inspect Tire Wear Pattern
Rotate Tires and Adjust Air Pressure
Replace
Engine Oil
Oil Filter

Lubrication Specifications

Application	Specification
Differential Gear Oil	
Maximum Temperature Less Than 104°F (40°C)	SAE 80W-90 API GL-5
Minimum Temperature Greater Than 104°F (40°C)	SAE 140 API GL-5
Engine Oil	
Preferred For All Ambient Temperatures	SAE 5W-30 API SG
Minimum Temperature Greater Than 32°F (0°C)	SAE 10W-30 Or 10W-40 API SG
Greater Than 50°F (10°C)	SAE 20W-40 Or 20W-50 API SG
Transmission	
Automatic Transmission	Nissan ATF Or Dexron-II ATF

Manual Transmission	
Maximum Temperature	
Less Than 104°F (40°C)	SAE 80W-90 API GL-4
Minimum Temperature	
Greater Than 104°F (40°C)	SAE 140 API GL-4
Fluid Capacities	
Application	(1) Quantity
Automatic Transmission Fluid	8.8 Qts. (8.3L)
Differential	
R200	1.4 Qts. (1.3L)
R200V	1.6 Qts. (1.5L)
Engine Oil (2)	3.7-4.0 Qts. (3.5-3.8L)
Manual Transmission Oil	2.5 Qts. (2.4L)
(1) - Capacities are recommended or calculated levels. Always use dipstick (if available) to measure level.	
(2) - Includes filter change.	
Service Labor Times	
Application	Hours
2.4L	1.5

82,500 MILE (132,000 KM) SERVICE

82,500 MILE (132,000 KM) SERVICE

Service Or Inspect	
	Verify Last Major Service Was Performed
	Check Fluid Levels
	Check Cooling System Hoses and Clamps
	Check Exhaust System & Heat Shielding
	Inspect Brake System
	Lubricate Chassis
	Inspect C/V Joint boots
	Inspect Steering Linkage/Front Suspension
	Rotate Tires and Adjust Air Pressure (Including Spare)
Replace	
	Engine Oil
	Oil Filter
Lubrication Specifications	
Application	Specification

Engine Oil	
Preferred For All	
Ambient Temperatures	SAE 5W-30 API SG
Minimum Temperature	
Greater Than 32°F (0°C)	SAE 10W-30 Or 10W-40 API SG
Greater Than 50°F (10°C)	SAE 20W-40 Or 20W-50 API SG
Fluid Capacities	
Application	(1) Quantity
Engine Oil (2)	3.7-4.0 Qts. (3.5-3.8L)
(1) - Capacities are recommended or calculated levels. Always use dipstick (if available) to measure level.	
(2) - Includes filter change.	

90,000 MILE (144,000 KM) SERVICE

90,000 MILE (144,000 KM) SERVICE

Service Or Inspect	
	Verify Last Major Service Was Performed
	Vapor Lines
	Fuel Lines
	Check Fluid Levels
	Check Cooling System Hoses and Clamps
	Clean Battery and Battery Terminals
	Inspect/Adjust Accessory Drive Belts (Replace if Required)
	Check Exhaust System & Heat Shielding
	ABS System Operation
	Brake Hoses & Lines
	Brake Discs & Calipers
	Rear Brake Drums, Wheel Cylinders & Linings
	Check Operation of Horn, Wipers/Washers & All Exterior Lights
	Inspect Condition of Wiper Blades
	Check Headlight Alignment
	Check Seat Belt Webbing and Release Mechanisms
	Check Parking Brake Operation
	Check Shift/Clutch Interlock Operation
	Inspect Spark Plug Wires

Inspect Distributor Cap
Inspect Fuel/Tank/Cap/Lines
Inspect C/V Joint boots
Inspect Power Steering System (If Equipped)
Suspension Mounting Bolts
Inspect Steering Linkage/Front Suspension
Super HICAS Linkage (If Equipped)
Lubricate Chassis
Inspect Front Brake Pads & Rotors
Inspect Rear Brake Linings & Drums
Inspect Brake System Hoses & Lines
Inspect Shocks/Struts for Leakage
Inspect Tire Wear Pattern
Lubricate Weatherstripping with Silicone
Lubricate Door Hinges
Lubricate Door Locks
Check Body Drain Holes
Rotate Tires and Adjust Air Pressure
Replace
Engine Oil
Oil Filter
Air Filter Element
Spark Plugs
Drain, Flush and Refill Engine Coolant

Lubrication Specifications

Application	Specification
Differential Gear Oil	
Maximum Temperature Less Than 104°F (40°C)	SAE 80W-90 API GL-5
Minimum Temperature Greater Than 104°F (40°C)	SAE 140 API GL-5
Engine Oil	
Preferred For All Ambient Temperatures	SAE 5W-30 API SG
Minimum Temperature Greater Than 32°F (0°C)	SAE 10W-30 Or 10W-40 API SG
Greater Than 50°F (10°C)	SAE 20W-40 Or 20W-50 API SG

Transmission	
Automatic Transmission	Nissan ATF Or Dexron-II ATF
Manual Transmission	
Maximum Temperature	
Less Than 104°F (40°C)	SAE 80W-90 API GL-4
Minimum Temperature	
Greater Than 104°F (40°C)	SAE 140 API GL-4
Fluid Capacities	
Application	(1) Quantity
Automatic Transmission Fluid	8.8 Qts. (8.3L)
Cooling System	6.3-7.1 Qts. (6.0-6.7L)
Differential	
R200	1.4 Qts. (1.3L)
R200V	1.6 Qts. (1.5L)
Engine Oil (2)	3.7-4.0 Qts. (3.5-3.8L)
Manual Transmission Oil	2.5 Qts. (2.4L)
(1) - Capacities are recommended or calculated levels. Always use dipstick (if available) to measure level.	
(2) - Includes filter change.	
Service Labor Times	
Application	Hours
2.4L	2.3

97,500 MILE (156,000 KM) SERVICE

97,500 MILE (156,000 KM) SERVICE

Service Or Inspect	
	Verify Last Major Service Was Performed
	Check Fluid Levels
	Check Cooling System Hoses and Clamps
	Check Exhaust System & Heat Shielding
	Inspect Brake System
	Inspect C/V Joint boots
	Inspect Steering Linkage/Front Suspension
	Lubricate Chassis
	Rotate Tires and Adjust Air Pressure (Including Spare)
Replace	
	Engine Oil
	Oil Filter
Lubrication Specifications	

Application	Specification
Engine Oil	
Preferred For All	
Ambient Temperatures	SAE 5W-30 API SG
Minimum Temperature	
Greater Than 32°F (0°C)	SAE 10W-30 Or 10W-40 API SG
Greater Than 50°F (10°C)	SAE 20W-40 Or 20W-50 API SG

Fluid Capacities

Application	(1) Quantity
Engine Oil (2)	3.7-4.0 Qts. (3.5-3.8L)

- (1) - Capacities are recommended or calculated levels. Always use dipstick (if available) to measure level.
(2) - Includes filter change.

105,000 MILE (168,000 KM) SERVICE

105,000 MILE (168,000 KM) SERVICE

Service Or Inspect
Verify Last Major Service Was Performed
Check Fluid Levels
Check Cooling System Hoses and Clamps
Check Coolant Strength
Check Exhaust System & Heat Shielding
Clean Battery and Battery Terminals
Inspect Brake System
Check Operation of Horn, Wipers/Washers & All Exterior Lights
Inspect Condition of Wiper Blades
Check Headlight Alignment
Check Seat Belt Webbing and Release Mechanisms
Check Parking Brake Operation
Brake Hoses & Lines
Brake Discs & Calipers
Suspension Mounting Bolts
Inspect Fuel/Tank/Cap/Lines
Check Shift/Clutch Interlock Operation
Inspect C/V Joint boots

Inspect Power Steering System (If Equipped)	
Inspect Steering Linkage/Front Suspension	
Lubricate Chassis	
Lubricate Weatherstripping with Silicone	
Lubricate Door Hinges	
Lubricate Door Locks	
Check Body Drain Holes	
Rotate Tires and Adjust Air Pressure	
Replace	
Engine Oil	
Oil Filter	
Lubrication Specifications	
Application	Specification
Differential Gear Oil	
Maximum Temperature	
Less Than 104°F (40°C)	SAE 80W-90 API GL-5
Minimum Temperature	
Greater Than 104°F (40°C)	SAE 140 API GL-5
Engine Oil	
Preferred For All	
Ambient Temperatures	SAE 5W-30 API SG
Minimum Temperature	
Greater Than 32°F (0°C)	SAE 10W-30 Or 10W-40 API SG
Greater Than 50°F (10°C)	SAE 20W-40 Or 20W-50 API SG
Transmission	
Automatic Transmission	Nissan ATF Or Dexron-II ATF
Manual Transmission	
Maximum Temperature	
Less Than 104°F (40°C)	SAE 80W-90 API GL-4
Minimum Temperature	
Greater Than 104°F (40°C)	SAE 140 API GL-4
Fluid Capacities	
Application	(1) Quantity
Automatic Transmission Fluid	8.8 Qts. (8.3L)
Differential	
R200	1.4 Qts. (1.3L)
R200V	1.6 Qts. (1.5L)
Engine Oil (2)	3.7-4.0 Qts. (3.5-3.8L)
Manual Transmission Oil	2.5 Qts. (2.4L)
(1) - Capacities are recommended or calculated levels. Always use dipstick (if available) to measure level.	
(2) - Includes filter change.	

112,500 MILE (180,000 KM) SERVICE

112,500 MILE (180,000 KM) SERVICE

Service Or Inspect	
	Verify Last Major Service Was Performed
	Check Fluid Levels
	Check Cooling System Hoses and Clamps
	Check Exhaust System & Heat Shielding
	Inspect C/V Joint boots
	Inspect Steering Linkage/Front Suspension
	Lubricate Chassis
	Rotate Tires and Adjust Air Pressure
Replace	
	Engine Oil
	Oil Filter
Lubrication Specifications	
Application	Specification
Engine Oil	
Preferred For All	
Ambient Temperatures	SAE 5W-30 API SG
Minimum Temperature	
Greater Than 32°F (0°C)	SAE 10W-30 Or 10W-40 API SG
Greater Than 50°F (10°C)	SAE 20W-40 Or 20W-50 API SG
Fluid Capacities	
Application	(1) Quantity
Engine Oil (2)	3.7-4.0 Qts. (3.5-3.8L)
(1) - Capacities are recommended or calculated levels. Always use dipstick (if available) to measure level.	
(2) - Includes filter change.	

120,000 MILE (192,000 KM) SERVICE

120,000 MILE (192,000 KM) SERVICE

Service Or Inspect	
	Verify Last Major Service Was Performed
	Vapor Lines
	Fuel Lines

	Check Fluid Levels
	Check Cooling System Hoses and Clamps
	Inspect/Adjust Accessory Drive Belts (Replace if Required)
	Check Exhaust System & Heat Shielding
	Clean Battery and Battery Terminals
	Inspect Underhood Wiring Harnesses and Connections
	Inspect Emission Control Vacuum Hoses and Connections
	Inspect Distributor Cap
	Evaporative Emission Control System
	Ignition Wiring
	Inspect Fuel/Tank/Cap/Lines
	Inspect C/V Joint boots
	Super HICAS Linkage (If Equipped)
	Inspect Power Steering System (If Equipped)
	Inspect Steering Linkage/Front Suspension
	Lubricate Chassis
	Suspension Bushings, Springs, Arms & Rear Jounce Bumpers
	Parking Brake System
	Brake Hoses & Lines
	Brake Discs & Calipers
	Rear Brake Drums, Wheel Cylinders & Linings
	Inspect Shocks for Leakage
	Inspect Tire Wear Pattern
	Rotate Tires and Adjust Air Pressure (Including Spare)
	Replace
	Engine Oil
	Oil Filter
	Spark Plugs
	Air Filter Element
	Drain, Flush and Refill Engine Coolant
	Lubrication Specifications
Application	Specification

Differential Gear Oil	
Maximum Temperature	
Less Than 104°F (40°C)	SAE 80W-90 API GL-5
Minimum Temperature	
Greater Than 104°F (40°C)	SAE 140 API GL-5
Engine Oil	
Preferred For All	
Ambient Temperatures	SAE 5W-30 API SG
Minimum Temperature	
Greater Than 32°F (0°C)	SAE 10W-30 Or 10W-40 API SG
Greater Than 50°F (10°C)	SAE 20W-40 Or 20W-50 API SG
Transmission	
Automatic Transmission	Nissan ATF Or Dexron-II ATF
Manual Transmission	
Maximum Temperature	
Less Than 104°F (40°C)	SAE 80W-90 API GL-4
Minimum Temperature	
Greater Than 104°F (40°C)	SAE 140 API GL-4
Fluid Capacities	
Application	(1) Quantity
Automatic Transmission Fluid	8.8 Qts. (8.3L)
Cooling System	6.3-7.1 Qts. (6.0-6.7L)
Differential	
R200	1.4 Qts. (1.3L)
R200V	1.6 Qts. (1.5L)
Engine Oil (2)	3.7-4.0 Qts. (3.5-3.8L)
Manual Transmission Oil	2.5 Qts. (2.4L)
(1) - Capacities are recommended or calculated levels. Always use dipstick (if available) to measure level.	
(2) - Includes filter change.	
Service Labor Times	
Application	Hours
2.4L	2.3

LUBRICATION SPECIFICATIONS

LUBRICATION SPECIFICATIONS TABLE

Application	Fluid Specifications
Brake Fluid	US FMVSS No. 116 Or DOT 3 Brake Fluid
Differential Gear Oil	
Maximum Temperature	
Less Than 104°F (40°C)	SAE 80W-90 API GL-5
Minimum Temperature	
Greater Than 104°F (40°C)	SAE 140 API GL-5
Engine Oil	
Preferred For All	
Ambient Temperatures	SAE 5W-30 API SH/CD
Minimum Temperature	
Greater Than 32°F (0°C)	SAE 10W-30 Or 10W-40 API SH/CD
Greater Than 50°F (10°C)	SAE 20W-40 Or 20W-50 API SH/CD
Power Steering Fluid	Dexron-II E ATF

Transmission
 Automatic Transmission Nissan ATF Or Dexron-IIIE ATF
 Manual Transmission
 Maximum Temperature
 Less Than 104°F (40°C) SAE 80W-90 API GL-4
 Minimum Temperature
 Greater Than 104°F (40°C) SAE 140 API GL-4

FLUID CAPACITIES

FLUID CAPACITIES TABLE (1)

Application	Quantity
A/C System R-12 Refrigerant	
1989	32-35 Ozs.
1990-94 (2)	29-32 Ozs.
A/C System R-134a Refrigerant (3)	
1994 (2)	29-32 Ozs.
Automatic Transmission Fluid	8.8 Qts. (8.3L)
Cooling System (4)	7.1 Qts. (6.7L)
Differential	
R200	1.4 Qts. (1.3L)
R200V	1.6 Qts. (1.5L)
Engine Oil (5)	4.0 Qts. (3.5L)
Fuel Tank	15.8 Gals. (60L)
Manual Transmission Oil	2.5 Qts. (2.4L)

- (1) - Capacities are recommended or calculated levels. Always use dipstick (if available) to measure level.
 (2) - A/C units from July 1993 may have R-134a, check vehicle for identification of refrigerant used.
 (3) - Use of R-12 in R134a systems will result in SEVERE DAMAGE
 (4) - Includes reservoir tank.
 (5) - Includes filter change.
-