

WIPER/WASHER SYSTEM

1990 Nissan 240SX

1990-92 ACCESSORIES & EQUIPMENT
Wiper/Washer Systems

Axxess, Maxima, Pathfinder, Pickup,
Pulsar NX, Sentra, Stanza, 240SX, 300ZX

NOTE: This article has been updated according to Technical Service
Bulletin No. TS89-115, dated August 10, 1989.

SYSTEM DESCRIPTION & OPERATION

All models are equipped with a 2-speed wiper system with time delay feature. Some models are equipped with a rear wiper/washer system.

WIPER MOTOR DESCRIPTION & OPERATION

All wiper motors include an integral park switch inside the motor housing. The motor cover can be removed and the switch adjusted if wipers do not park correctly. Some models have an externally mounted circuit breaker to protect the wiper motor.

WIPER AMPLIFIER DESCRIPTION & OPERATION

Axxess, Pathfinder, Pulsar NX and Sentra use a wiper amplifier to control the delayed front wiper cycle. The amplifier is a solid-state unit which interrupts current flow to the motor. The time delay is either fixed or adjustable with a knob at the end of the wiper stalk. Some models use an amplifier in the rear wiper circuit. See WIPER COMPONENT LOCATION table.

All Maxima, Stanza, 240SX and 300ZX models have a Time Control Unit (TCU) which controls the delayed wiper cycle. This unit also operates the clock, turn and hazard flashers, seat belt chimes and other timed delayed circuits.

WASHER DESCRIPTION & OPERATION

NOTE: A check valve is located in washer line between reservoir tank and nozzle. If removed, install valve with arrow toward nozzle.

All models have windshield washer systems. A separate pump is used for the rear washer. On all models except Maxima, a common reservoir is used for both washer systems. Maxima models have a rear washer reservoir mounted in luggage compartment.

NOTE: Not all vehicles have front or rear wiper relays or amplifiers.

WIPER COMPONENT LOCATION TABLE

Application	Location
1990 Axxess	
Amplifier	
Front	Underhood, Near Prop Rod
Rear	Right Side Rear Panel

Relay
 Rear Under Dash, Behind Glove Box

Maxima
 Relay Left Front Underhood, In Relay Box
 Time Control Unit Under Dash, Near Steering Column

Pathfinder
 Amplifier
 Rear Left Side Middle Panel
 Relay
 Rear Left Side Rear Panel

Pulsar NX
 Amplifier Underhood, Left Side Firewall

Sentra
 Amplifier Underhood, Left Side Firewall

Stanza
 Relay Left Front Underhood, In Relay Box
 Time Control Unit Left Side Kick Panel

240SX
 Amplifier
 Front Location Not Available From Manufacturer
 Rear Center Rear Panel
 Time Control Unit Left Side Kick Panel

300ZX
 Amplifier
 Front Left Rear Engine Compartment
 Time Control Unit Left Side Kick Panel

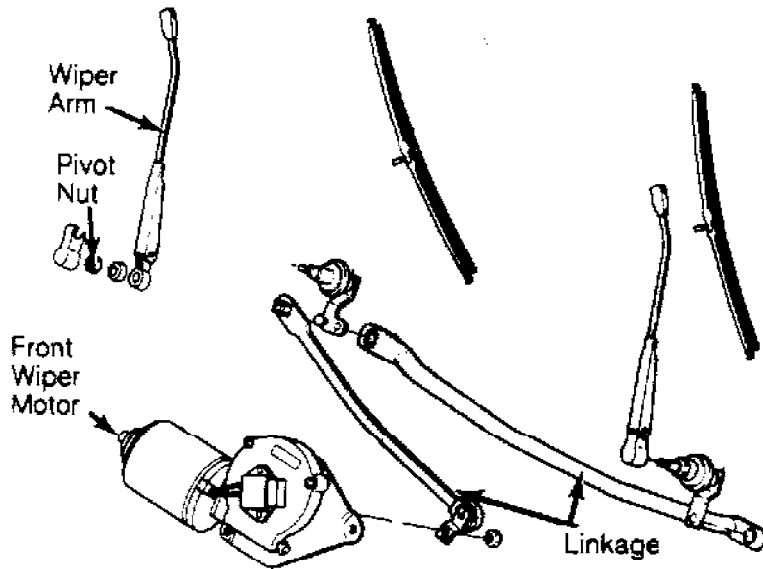

Courtesy of Nissan Motor Co., U.S.A.

Fig. 1: Typical Wiper/Washer Components
 Courtesy of Nissan Motor Co., U.S.A.

WIPER ARM ADJUSTMENT

1) Prior to installing wiper arm, turn wiper motor switch ON then OFF (Auto Stop). Install wiper arm but do not tighten nut. Set blade down on glass.

2) Set blade so that centerline of wiper blade is at specified distance from edge of glass in the STOP position (horizontal stop wipers). On vertical stop wipers, the distance is measured from centerline of wiper blade to edge of black print on glass. See WIPER BLADE CLEARANCE table. Tighten wiper arm nut.

3) Operate washer motor to spray washer fluid on glass. Turn wiper switch ON to operate wiper motor. Turn wiper switch OFF. Ensure proper clearance is maintained.

WIPER BLADE CLEARANCE TABLE

Application	Clearance In. (mm)
Axxess	
Front	
Left	1.9-2.3 (49-59)
Right	0-.4 (0-10)
Rear	
Horizontal Stop Type	1.4-1.8 (35-45)
Vertical Stop Type	1.0 (24)
Maxima	
Left	1.7-2.1 (43-53)
Right9-1.3 (22-32)
Pathfinder & Pickup	
Front8-1.2 (20-30)
Rear	Rests On Blade Lifter
Pulsar NX	0-.2 (0-5)
Sentra	
Front6-1.2 (16-31)
Rear	
Coupe6-1.0 (15-25)
Wagon	1.0-1.4 (25-35)
1991 Sentra	
Front	
Left98-1.38 (25-35)
Right79-1.18 (20-30)
Rear	4.13-4.53 (105-115)
Stanza	
Left	1.7-2.1 (43-53)
Right9-1.3 (22-32)
240SX	
Front7-1.3 (25-35)
Rear	1.0-1.4 (25-35)
300ZX	
Front	0-.4 (0-10)
Rear	2.9-3.5 (73-88)

WIPER SWITCH TEST

For wiper switch testing, see STEERING COLUMN SWITCHES article in the ACCESSORIES & EQUIPMENT section.

WIPER AMPLIFIER TEST

AXXESS, PATHFINDER, PULSAR, SENTRA, 240SX & 300ZX

1) Disconnect and remove amplifier from vehicle or position so test leads, battery and test light can be connected to amplifier terminals. Use care to prevent improper connections since amplifier can be damaged.

2) Connect test leads and test light as shown to battery and terminals of amplifier. See Fig. 2. Leaving test lead from terminal No. 6 for last, connect test lead to battery ground. If test light comes on, amplifier is normal. If not, replace amplifier.

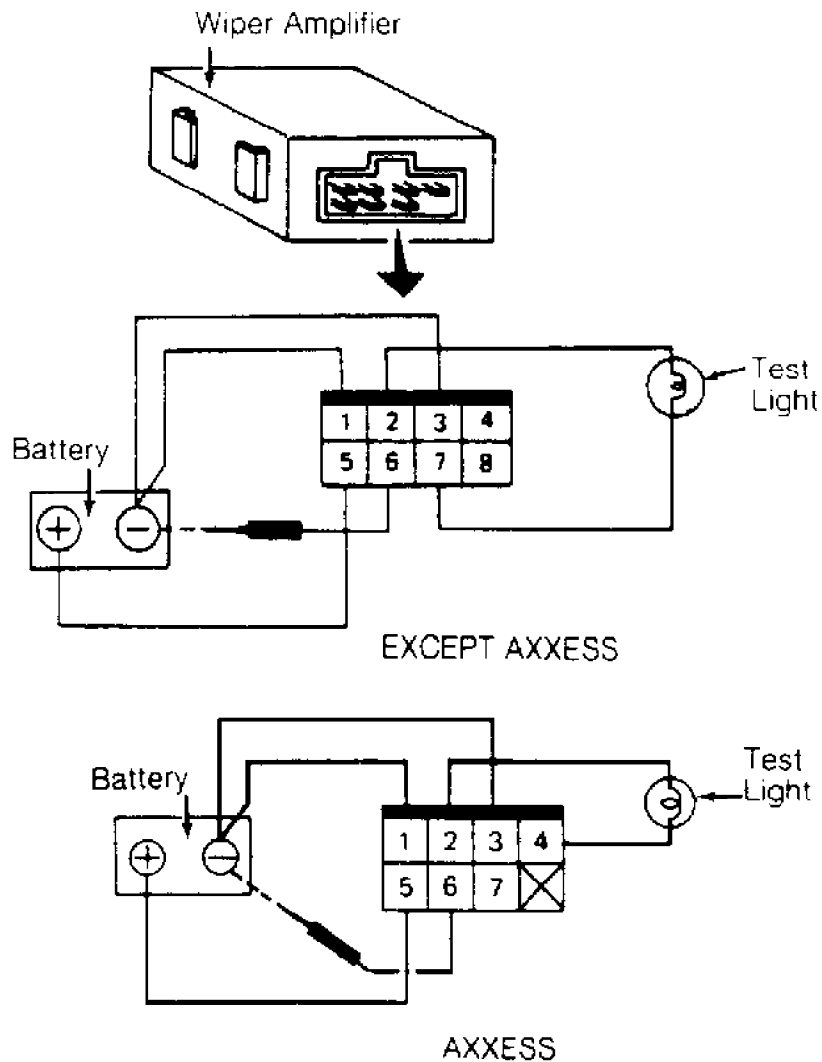
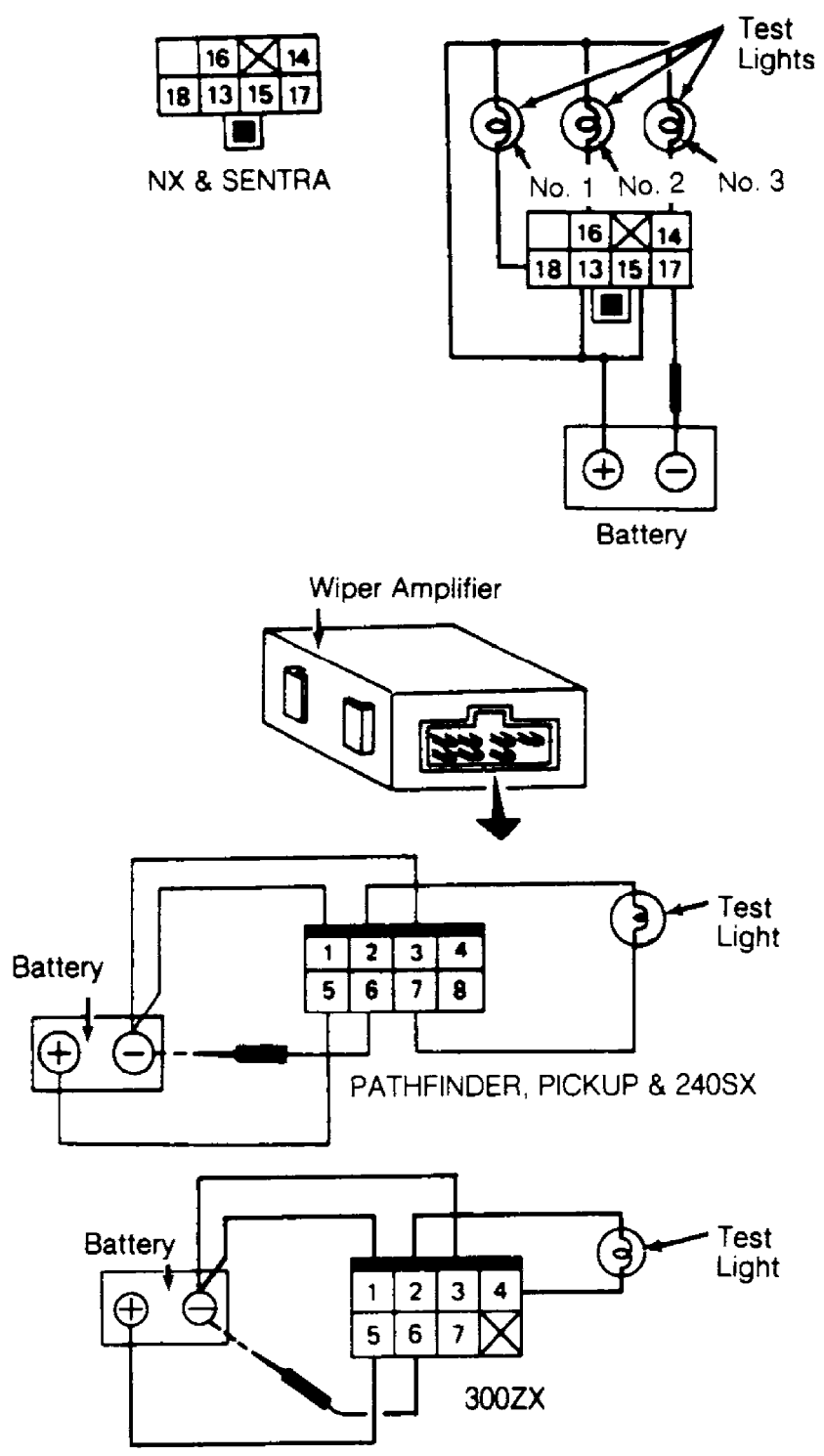

Fig. 2: Testing Wiper Amplifier
Courtesy of Nissan Motor Co., U.S.A.



92E00939

Fig. 3: Testing Wiper Amplifier (Except Axxess)
 Courtesy of Nissan Motor Co., U.S.A.

WIPER RELAY TEST

Connect test leads and test light as shown to battery and to terminals of wiper relay. See Fig. 4. Leaving test lead from terminal No. 6 for last, connect test lead to battery ground. Relay is normal if test light comes on. If test light does not come on, replace wiper relay.

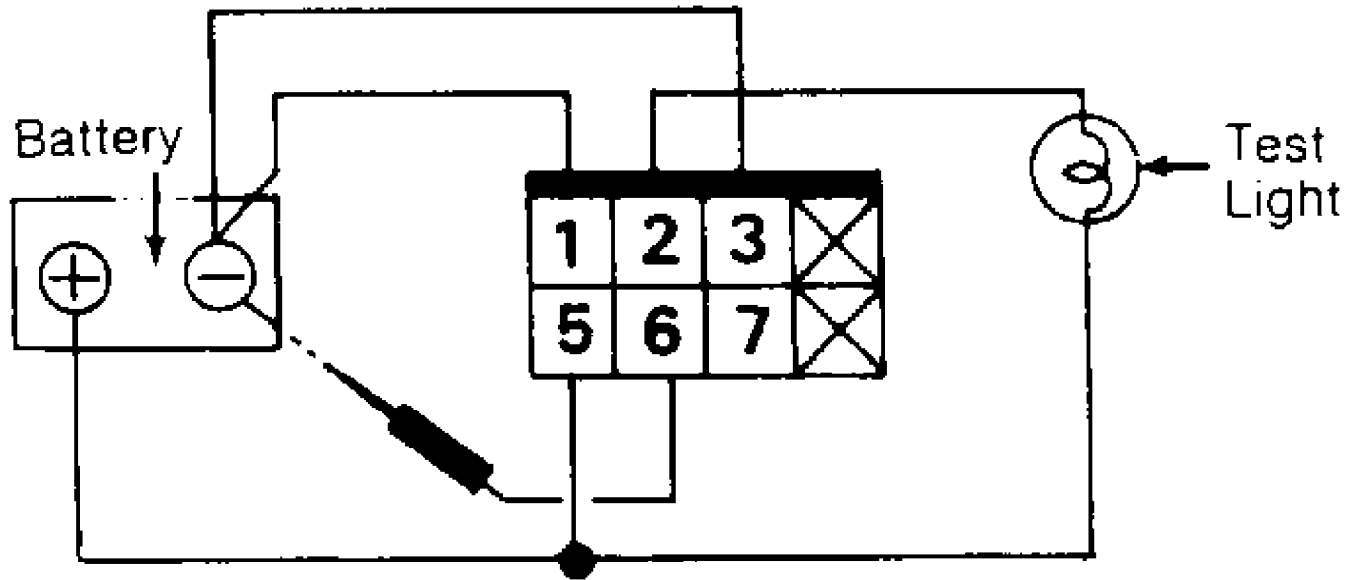
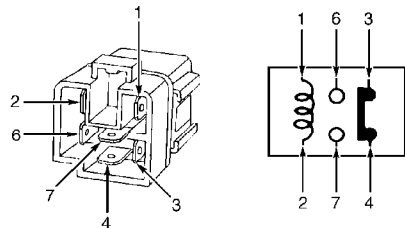

Fig. 4: Testing Wiper Relay
Courtesy of Nissan Motor Co., U.S.A.

WIPER RELAY TEST (1992 MODELS)

Remove relay. There should be continuity between terminals No. 3 and 4, and no continuity between terminals No. 6 and 7. See Fig. 5. Apply battery voltage across terminals No. 1 and 2. There should now be no continuity between terminals No. 3 and 4, and continuity between terminals No. 6 and 7. If continuity is not as specified, replace relay.



93G01936
Fig. 5: Testing Wiper Relay
Courtesy of Nissan Motor Co., U.S.A.

TIME CONTROL UNIT TEST

NOTE: The Time Control Unit (TCU) is used on Maxima, Stanza, 240SX and 300ZX models. Control unit operates many different systems for each vehicle. The following circuit test procedures only check circuits that control the wiper delay operation.

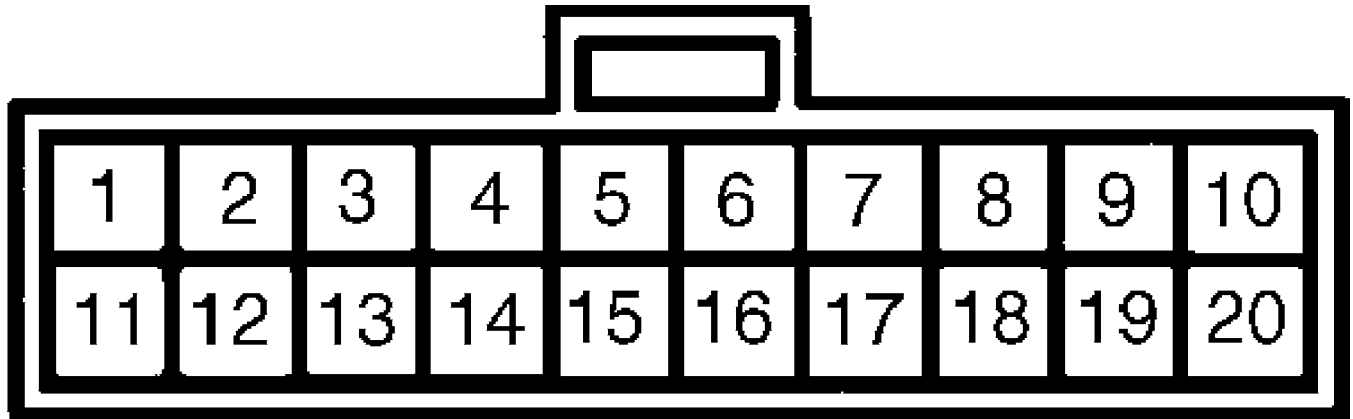

91A00166

Fig. 6: Harness Connectors On Time Control Unit
Courtesy of Nissan Motor Co., U.S.A.

When testing time control unit, insert probes into harness side of connector while still plugged into control unit. See Figs. 4 and 5. Ensure ignition key is in correct position when testing each circuit. Perform tests in order:

- * Power Circuit
- * TCU Output Wiper Relay Circuit
- * Wiper Switch Circuit
- * Intermittent Wiper Volume

POWER CIRCUIT

1) Turn ignition off. Access time control unit with harness still connected. Using an ohmmeter, check continuity between terminal No. 15 and ground. Continuity should exist. If not, inspect TCU harness circuit and repair or replace as needed.

2) Connect a voltmeter between terminals No. 9 (+) and 15 (-) at harness side of connector. Voltmeter should show 12 volts when ignition switch is in any position.

3) Connect voltmeter to terminals No. 5 (+) and 15 (-). With ignition switch in the OFF or ACC position, voltmeter should show zero volts. With ignition switch in the ON position, voltmeter should show 12 volts. If results are incorrect, inspect TCU harness circuit. If correct, test TCU output wiper relay circuit.

4) Connect voltmeter leads to terminals No. 2 (+) and 15 (-). With ignition switch in the ACC or ON position, voltmeter should read 12 volts. There should be no voltage reading when ignition switch is in the OFF position. If results are incorrect, inspect TCU harness circuit. If correct, test TCU output wiper relay circuit.

TCU OUTPUT WIPER RELAY CIRCUIT

Turn ignition switch to the ACC position and wiper switch in the INT position, measure voltage across terminals No. 1 (+) and

15 (-). Voltage reading should be zero volts, then should read 12 volts in 3 to 12 second intervals. If not, check wiper switch circuit.

WIPER SWITCH CIRCUIT

Turn ignition switch to the OFF position and wiper switch to the INT position. Using an ohmmeter, check for continuity between terminals No. 12 (+) and 15 (-). Continuity should exist. If not, check wiper switch.

INTERMITTENT WIPER VOLUME CIRCUIT

Turn ignition off. Using an ohmmeter, measure resistance between terminals No. 14 and 15 while turning intermittent wiper volume switch. Reading should be from zero ohms with switch in the "S" position, and should read approximately one ohm in the "L" position. If reading is incorrect, replace wiper switch.

FRONT WIPER MOTOR R & I

Removal

- 1) Disconnect battery ground cable and motor wiring. Remove wiper motor mounting bolts. Remove nut and clip holding linkage arm to motor shaft. Remove motor assembly.
- 2) Remove wiper arm cap and nut. Remove wiper arm and wiper shaft nut. Remove inspection cover (if equipped) and remove linkage.

NOTE: Before installing wiper arm(s), wiper motor must be cycled at lowest speed, then turned off to allow motor to find its parked position.

Installation

- 1) Clean wiper arm splines (on each pivot actuator) with a wire brush before installing wiper arm. To install, reverse removal procedure.
- 2) On some models, wiper arm lengths differ from side to side. Compare arm lengths before installation. Driver's side arm can be identified by a "D" and is usually the shorter arm. The passenger's side arm can be identified by an "A" and is usually the longer arm.
- 3) Ensure clearance (position) of wiper blade is correct when installing wiper arms. Clearance is measured between edge of windshield and end of wiper blade. See WIPER BLADE CLEARANCE table.

WIPER RELAYS R & I

For removal and installation of wiper relays, see WIPER COMPONENT LOCATION table in this article. Remove panels and fasteners as necessary. To install, reverse removal procedure.

REAR WIPER MOTOR R & I

Removal

Remove wiper shaft nut and wiper arm. Open hatch or tailgate and remove inner panel. Disconnect wiring from motor. Remove motor mounting bolts. Remove wiper motor.

Installation

To install, reverse removal procedure. Install wiper arm so blade is in correct position. See WIPER BLADE CLEARANCE table.

COMBINATION SWITCH R & I

Remove steering wheel pad and steering wheel. Disconnect all wiring. Remove retaining screw or clip and pull combination switch off column. Wiper switches can be separated from combination switch. To install, reverse removal procedure. Align tab on switch with hole in column.

WIRING DIAGRAMS

See appropriate chassis wiring diagram in WIRING DIAGRAMS.

TORQUE SPECIFICATIONS

WIPER ARM TORQUE SPECIFICATIONS

Application	FT Lbs. (N.m)
*Axxess	
Front	9-13 (12-18)
Maxima	12-17 (17-23)
Pathfinder & Pickup	10-13 (14-18)
Pulsar NX	10-13 (14-18)
Sentra	10-13 (14-18)
Stanza	12-17 (17-23)
240SX	
Front	12-17 (17-23)
Rear	10-13 (14-18)
300ZX	
Front	12-17 (17-23)
	INCH Lbs. (N.m)
Axxess	
Rear	56-104 (6-12)
300ZX	
Rear	78-104 (9-12)

* Revised according to Technical Service Bulletin
No. TS89-115