

# WIRING DIAGRAMS

1990 Nissan 240SX

1990 Wiring Diagrams  
Nissan

240SX

## IDENTIFICATION

### COMPONENT LOCATION MENU

#### COMPONENT LOCATIONS TABLE

Component	Figure No. (Location)
A/C RELAY .....	5 (D-E 17)
ABS ACTUATOR .....	7 (D-E 27)
ABS CONTROL UNIT .....	7 (D-E 24)
ACCESSORY RELAY #1 .....	3 (A 9)
ACCESSORY RELAY #2 .....	3 (A 8)
AIV SOLENOID .....	2 (A 5)
ALTERNATOR .....	1 (C-D 2)
AUTO ANTENNA TIMER .....	6 (C-D 20)
AUTOMATIC SEAT BELT CONTROL UNIT .....	7 (A 25-26)
AUTOMATIC TRANS CTRL UNIT (A/T CTRL UNIT) ....	4 (A 13-14)
BACK-UP LT SW .....	8 (C 30)
BATTERY .....	1 (A 2-3)
BLOWER MOTOR .....	5 (E 17)
BLOWER RELAY .....	3 (C 8)
BRAKE FLUID LEVEL SW .....	6 (E 21)
BULB CHECK RELAY .....	6 (D 20)
CHECK CONN .....	2 (A-B 7)
CIG LTR .....	3 (C 8)
CLUTCH INTERLOCK SW .....	3 (B 11)
COMB FLASHER .....	5 (D 16)
CRUISE CTRL HOLD RLY .....	4 (D 13)
CRUISE CTRL STEERING SW .....	4 (C-D 15)
CRUISE CTRL SW .....	4 (E 13)
CRUISE CTRL UNIT .....	4 (D-E 15)
DIODE BOX .....	6 (E 20)
DIR LT SW .....	5 (D 16)
DOOR LOCK TIMER .....	8 (A 28)
DOOR SWS .....	8 (E 29)
ECCS CTRL UNIT .....	2 (A-E 4)
ECCS RELAY .....	2 (A 4-5)
ENGINE TEMP SENS .....	2 (D 7)
EXHAUST GAS TEMP SENS .....	2 (C 5)
FAN SW .....	5 (D-E 16)
FICD SOL .....	2 (A 6)
FOG LT RELAY .....	1 (C 1-2)
FOG LT SW .....	5 (C 17)
FUEL PUMP RELAY .....	2 (A 7)
FUEL TANK UNIT .....	6 (B 20)
FUS LINKS .....	1 (B-C 3)
FUSE BLOCK .....	3 (B-D 9-10)
GLOVE BOX LT SW .....	5 (C 19)
HAZARD SW .....	5 (C 16)
HEADLT SW .....	5 (A 16)
HEADLT TIMER .....	5 (B 16)
HORN RELAY .....	1 (C 1)
IGNITION COIL .....	2 (C 7)

IGN RELAY .....	3	(A 9-10)
IGN SW .....	3	(A 11)
ILLUM CONTROL SW .....	5	(B 19)
INHIBITOR RELAY .....	4	(D 13)
INHIBITOR SW .....	4	(A-B 12)
INSTRUMENT CLUSTER .....	6	(A-E 23)
INTERIOR LIGHT .....	8	(E 28-29)
INTERLOCK RELAY .....	3	(B 10)
KEY SW .....	4	(E 12)
LEFT RETRACT MOTOR .....	1	(D 1)
NEUTRAL SW .....	2	(E 4)
OIL PRES SW .....	6	(A-B 20)
OVERDRIVE INDICATOR .....	4	(C 12)
OVERDRIVE SW .....	4	(C 12)
PARK BRAKE SW .....	6	(E 20)
POWER MIRROR SW .....	7	(C 24)
POWER WINDOW MAIN SW .....	7	(C 27)
PUSH CTRL UNIT .....	5	(D-E 19)
REAR WDO DEFOGGER RLY .....	8	(E 29)
REAR WDO DEFOGGER SW .....	8	(D-E 29)
REAR WIPER/WASHER SYSTEM .....	8	(B-C 28-29)
RELAY BOX (PARTIAL) .....	1	(B-C 3)
RESISTOR .....	2	(B 7)
RETRACT RELAYS #1-#2-#3-#4 .....	1	(D-E 3)
RETRACT SW .....	5	(B 16)
RIGHT RETRACT MOTOR .....	1	(A-B 1)
SHIFT LOCK CTRL UNIT .....	4	(D-E 12)
SPEED SENSOR .....	6	(A 20)
STARTER MOTOR .....	1	(A 3)
STOP LT SW .....	8	(B 29)
SUNROOF SYSTEM .....	8	(D 28-29)
TEMP SENSOR .....	6	(A 20)
THROTTLE POSITION SENSOR .....	2	(D-E 7)
THROTTLE VALVE SW .....	2	(E 7)
WASHER FLUID LEVEL SW .....	6	(D 21)
WASHER MOTOR .....	3	(E 9)
WIPER AMP .....	3	(D-E 11)
WIPER/WASHER SW .....	3	(E 8)

---

## WIRING DIAGRAMS

**COMPONENT LOCATOR:**

A/C RELAY	D-E 17
ABS ACTUATOR	D-E 27
ABS CTRL UNIT	D-E 24
ACCESSORY RELAY #1	A 8
ACCESSORY RELAY #2	A 9
AIV SOL	A 5
ALTERNATOR	C-D 2
AUTO ANTENNA TIMER	C-D 20
AUTOMATIC SEAT BELT CONTROL UNIT	A 25-26
AUTOMATIC TRANSMISSION CONTROL UNIT	A 13-14
BACK-UP LT SW	C 30
BATTERY	A 2-3
BLOWER MOTOR	A 17
BLOWER RELAY	C 4
BRAKE FLUID LEVEL SW	E 21
BULB CHECK RELAY	D 20
CHECK CONN.	A 20
CIG LTR	C 8
CLUTCH INTERLOCK SW	B 11
COMB FLASHER	C 16
CRUISE CTRL HOLD RELAY	D 13
CRUISE CTRL STEERING SW	D-D 16
CRUISE CTRL SW	E 13
CRUISE CTRL UNIT	D-E 19
DIPD BOX	E 20
DIR LT SW	A 28
DOOR LOCK TIMER	E 29
DOOR SWS	A-E 4
ECCS CTRL UNIT	A-E 4
ECCS RELAY	D 7
ENG NE TEMP SENS	C 5
EXHAUST GAS TEMP SENS	D-E 18
FAN SW	A 8
F-C-D SOL	C 1-2
FOG LT RELAY	C 17
FOG LT SW	A 7
FUEL PLUMP RELAY	B 20
FUEL TANK UNIT	B-C 3
FUS LINKS	B-D 9-10
FUSE BLOCK	C 19
GLOVE BOX LT SW	C 16
HAZARD SW	A 16
HEADLT SW	B 16
HORN RELAY	C 1
HORN SW	A 9-10
IGNITION COIL	A 11
IGNITION RELAYS	D 13
IGNITION SW	A 11
ILLUM CTRL SW	B 19
INHIBITOR RELAY	D 13
INHIBITOR SW	A-B 12
INSTRUMENT CLUSTERS	A-E 23
INTERIOR LTS	E 28-29
INTERLOCK RELAY	B 10
KEY SW	E 12
LEFT RETRACT MOTOR	D 1
NEUTRAL SW	E 4
OIL PRES SW	A 30
OVERDRIVE IND	C 12
OVERDRIVE SW	C 12
PARK BRAKE SW	E 20
POWER MIRROR SW	C 24
POWER WINDOW MAIN SW	C 27
PJSH CTRL UNIT	D-E 19
REAR WINDOW DEFOGGER RELAY	D 29
REAR WINDOW DEFOGGER SW	D 29
REAR WIPER/WASHER SYSTEM	B-C 28-29
RELAY BOX (PARTIAL)	B-C 3
RESISTOR	D 3
RETRACT RELAYS #1-#2-#3-#4	B 7
RETRACT SW	B 16
RIGHT RETRACT MOTOR	A-B 1
SHIFT LOCK CTRL UNIT	D-E 12
SPEED SENS	A 20
STARTER MOTOR	A 3
STOP LT SW	B 28
SUNROOF SYSTEM	D 28-29
TEMP SENS	D-E 7
THROTTLE POSITION SENS	E 7
THROTTLE VALVE SW	D 21
WASHER FLUID LEVEL SW	E 9
WASHER MOTOR	D-E 11
WIPER AMP	E 8
WIPER/WASHER SW	E 8

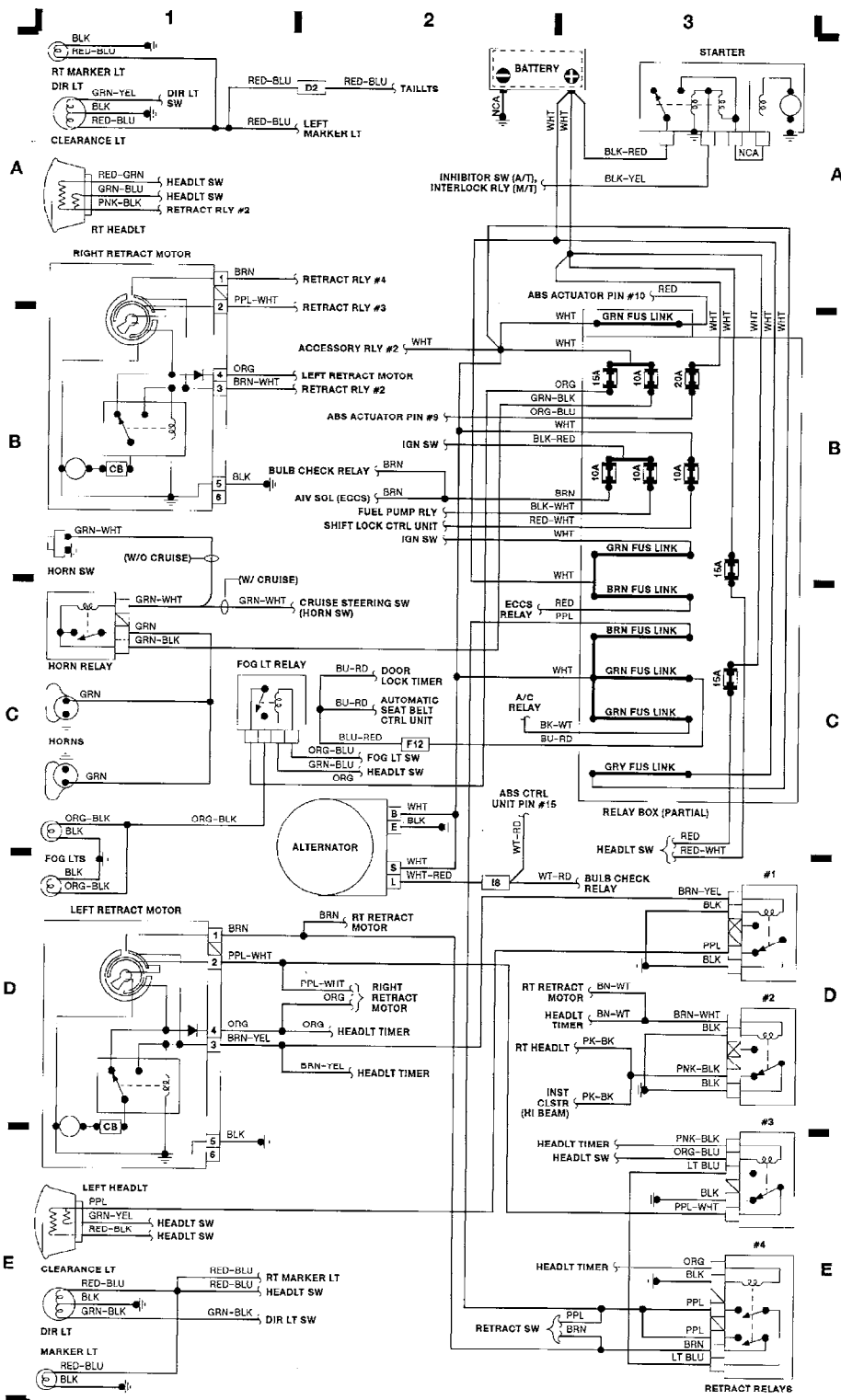

Fig. 1: Engine Compartment & Headlights (Grids 1-3)

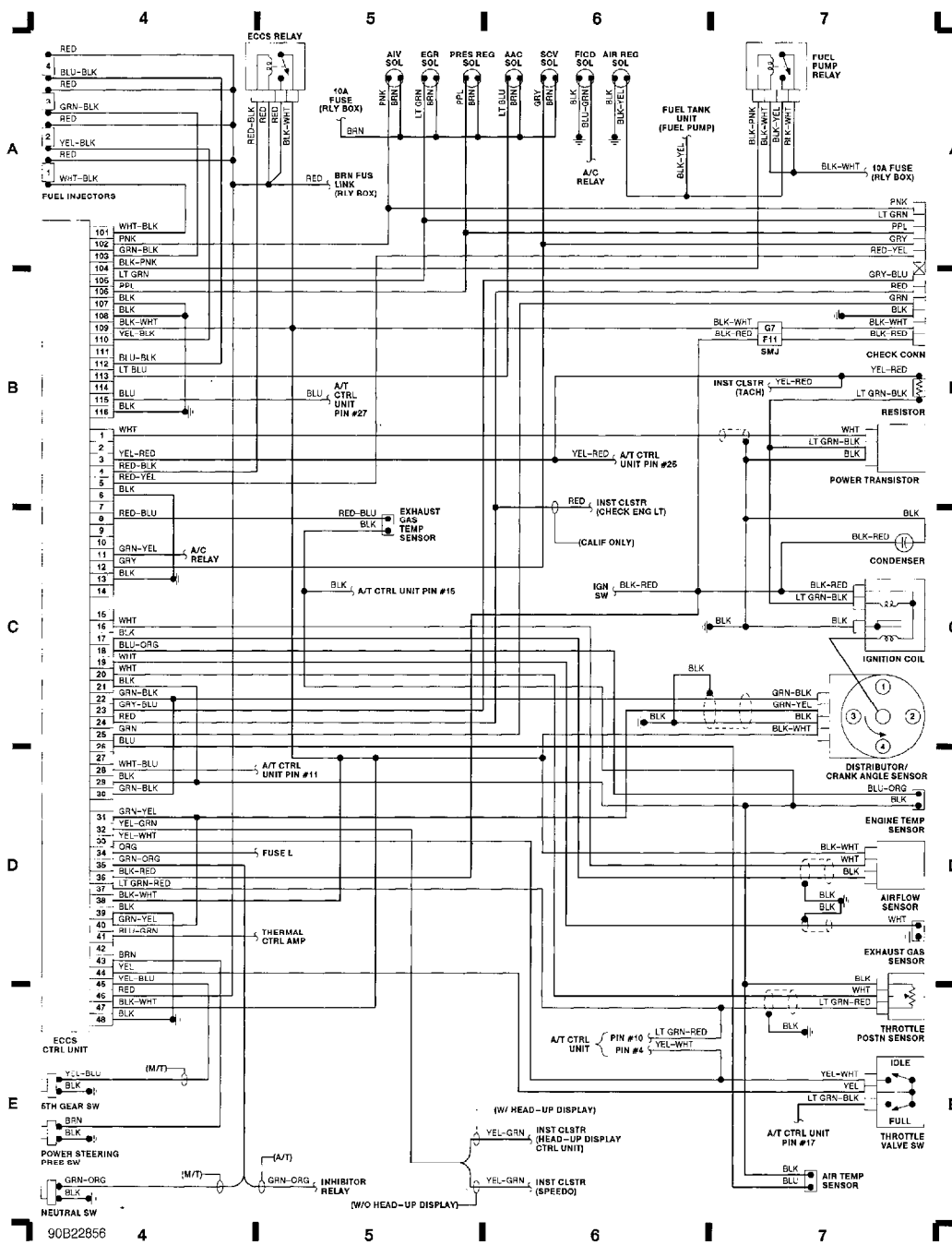

Fig. 2: Computer Engine Control (Grids 4-7)

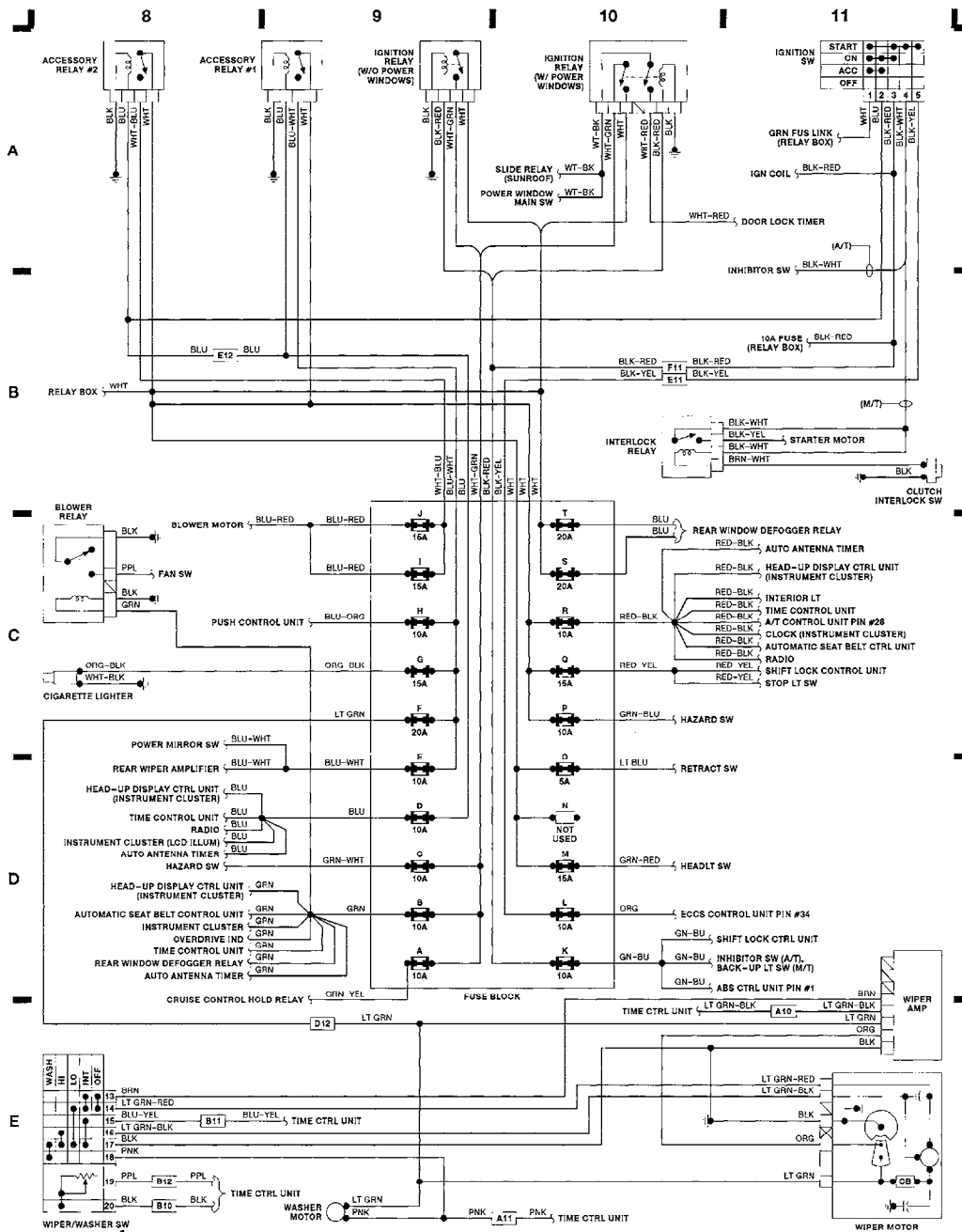

Fig. 3: Fuse Block (Grids 8-11)

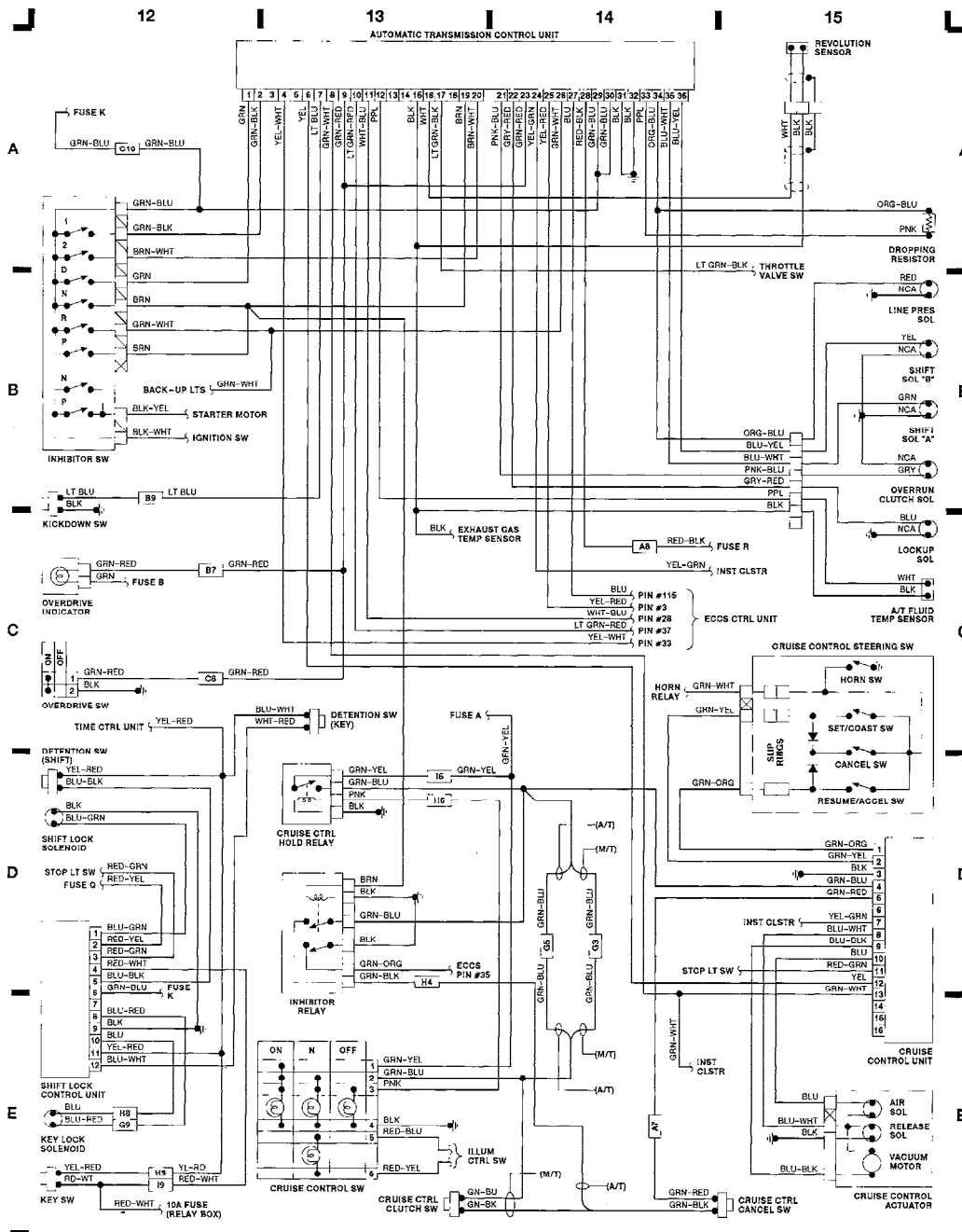

Fig. 4: Elect A/T Control, Cruise Control (Grids 12-15)

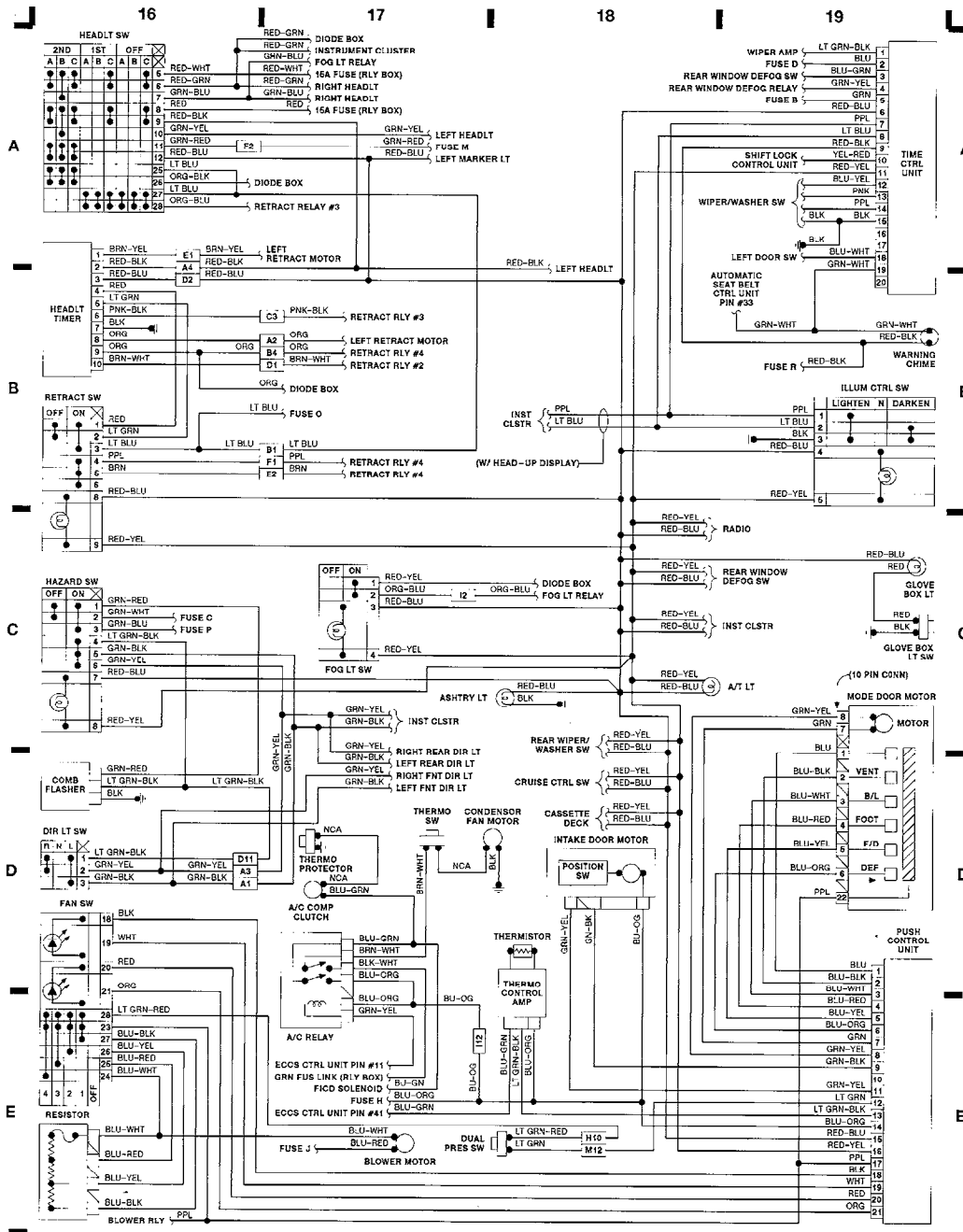

Fig. 5: A/C & Heater, Steering Column (Grids 16-19)

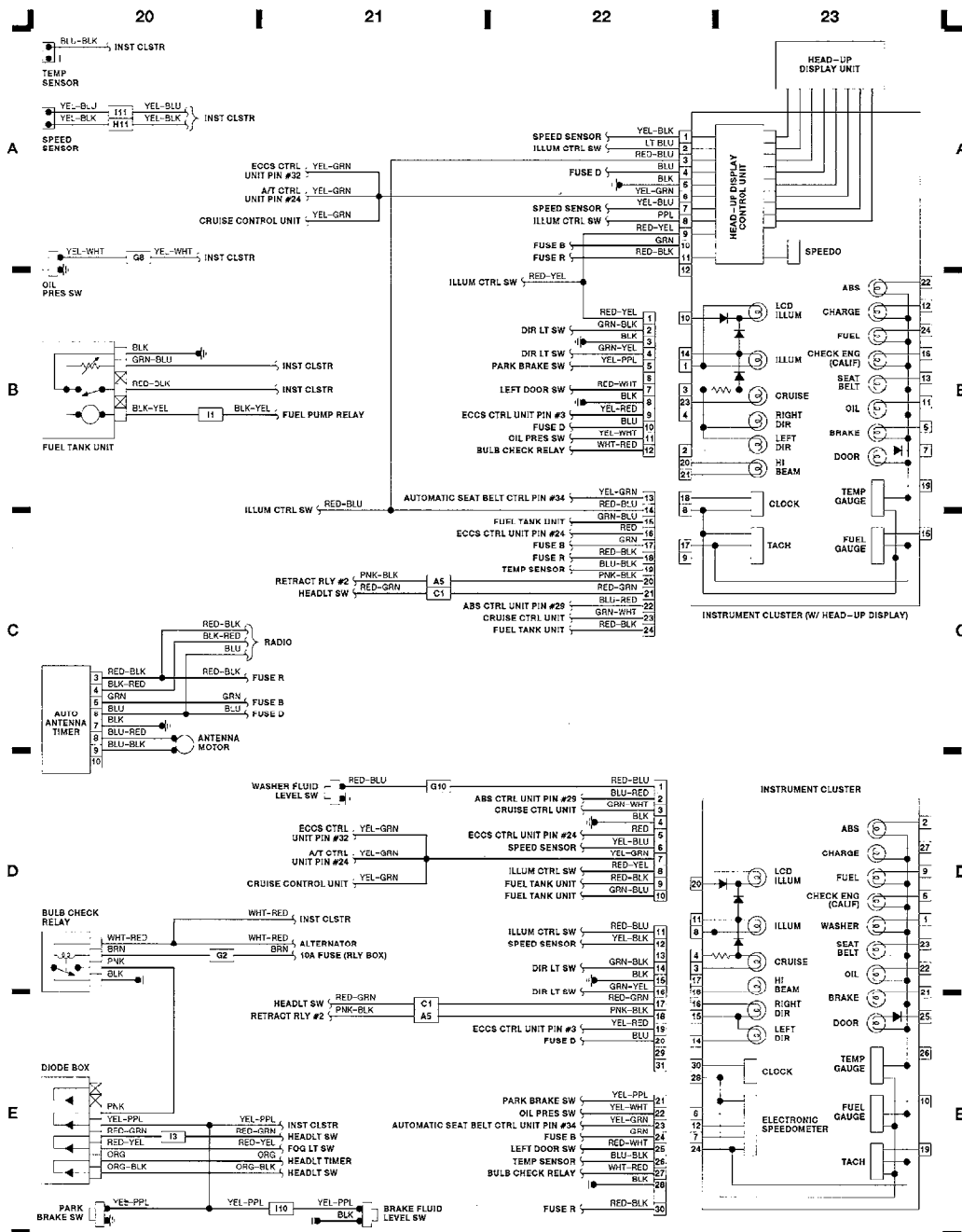

Fig. 6: Instrument Panel (Grids 20-23)



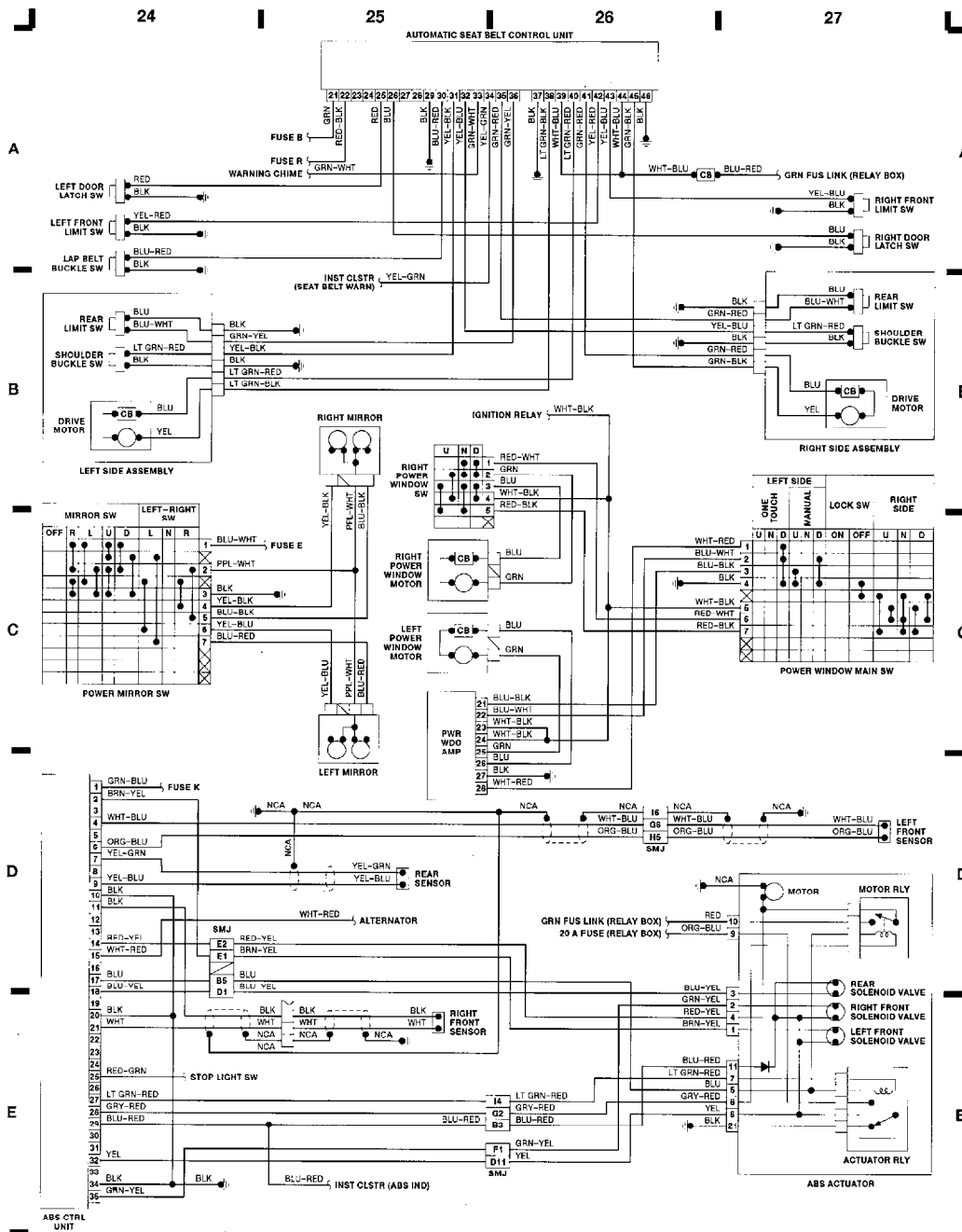

Fig. 7: ABS, Auto Seat Belts System (Grids 24-27)

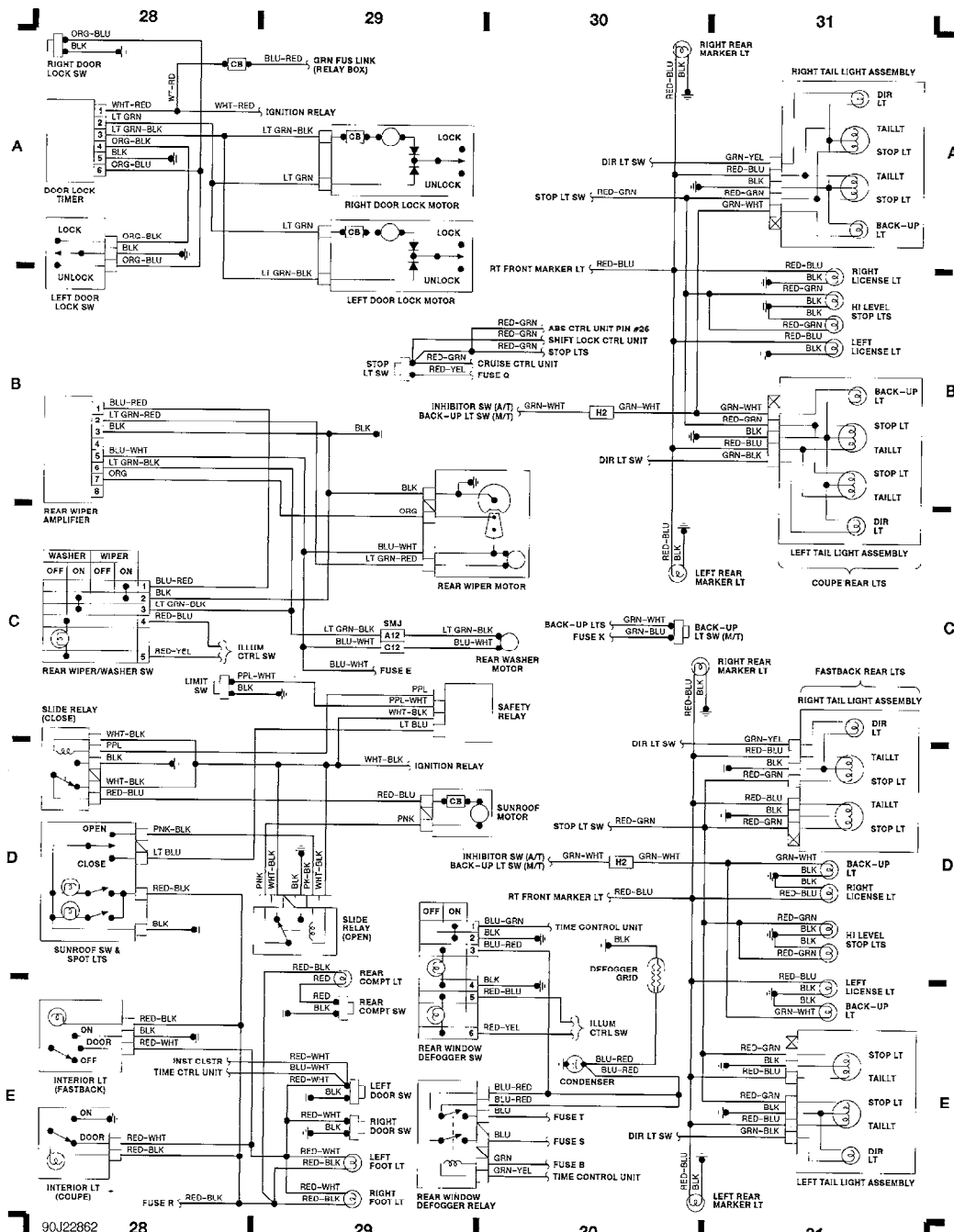

Fig. 8: Rear Wiper/Washer, Sunroof, Taillights (Grids 28-31)