

# ACCELERATOR CONTROL, FUEL & EXHAUST SYSTEMS

## SECTION **FE**

GI

MA

EM

LC

EF &  
EC

**FE**

CL

MT

AT

PD

FA

RA

BR

ST

BF

HA

EL

## CONTENTS

<b>ACCELERATOR CONTROL SYSTEM</b> .....	2	<b>FUEL SYSTEM</b> .....	3
Adjusting Accelerator Cable .....	2	<b>EXHAUST SYSTEM</b> .....	4

# ACCELERATOR CONTROL SYSTEM

## CAUTION:

- When removing accelerator cable, make a mark to indicate lock nut's initial position.
- Check that throttle valve opens fully when accelerator pedal is fully depressed and that it returns to idle position when pedal is released.
- Check accelerator control parts for improper contact with any adjacent parts.
- When connecting accelerator cable, be careful not to twist or scratch its inner wire.
- Refer to section EL for A.S.C.D. cable adjustment.
- Refer to "ON-VEHICLE SERVICE" in section AT for Kickdown switch adjustment.

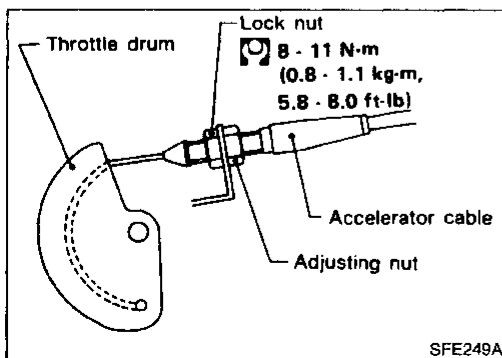
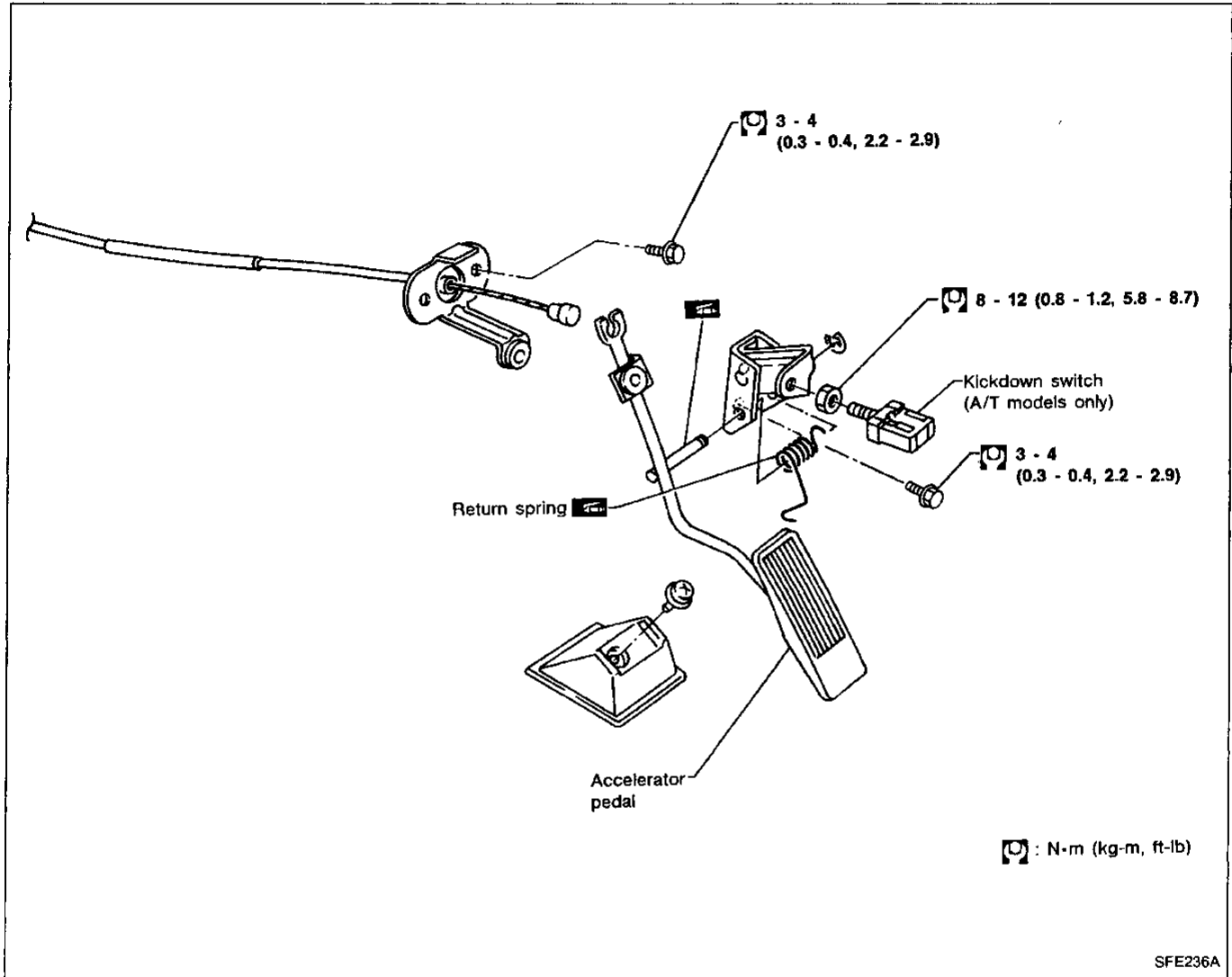

## Adjusting Accelerator Cable

1. Loosen lock nut, and tighten adjusting nut until throttle drum starts to move.
2. From that position turn back adjusting nut 1.5 to 2 turns, and fasten it with lock nut.

# FUEL SYSTEM

## WARNING:

When replacing fuel line parts, be sure to observe the following:

- Put a "CAUTION: INFLAMMABLE" sign in workshop.
- Do not smoke while servicing fuel system. Keep open flames and sparks away from work area.
- Be sure to disconnect battery ground cable before conducting operations.
- Be sure to furnish workshop with a CO<sub>2</sub> fire extinguisher.
- Put drained fuel in an explosion-proof container and put lid on securely.

## CAUTION:

- For electric fuel pump model, before disconnecting fuel hose, release fuel pressure from fuel line. Refer to "Changing Fuel Filter" in section MA.
- Do not disconnect any fuel line unless absolutely necessary.
- Plug hose and pipe openings to prevent entry of dust or dirt.
- Always replace O-ring and clamps with new ones.
- Do not kink or twist hose and tube when they are installed.
- Do not tighten hose clamps excessively to avoid damaging hoses.
- When installing fuel check valve, be careful of its designated direction. (Refer to section EF & EC.)
- Tighten bolts to specified torque.
- After installation, run engine and check for leaks at connections.

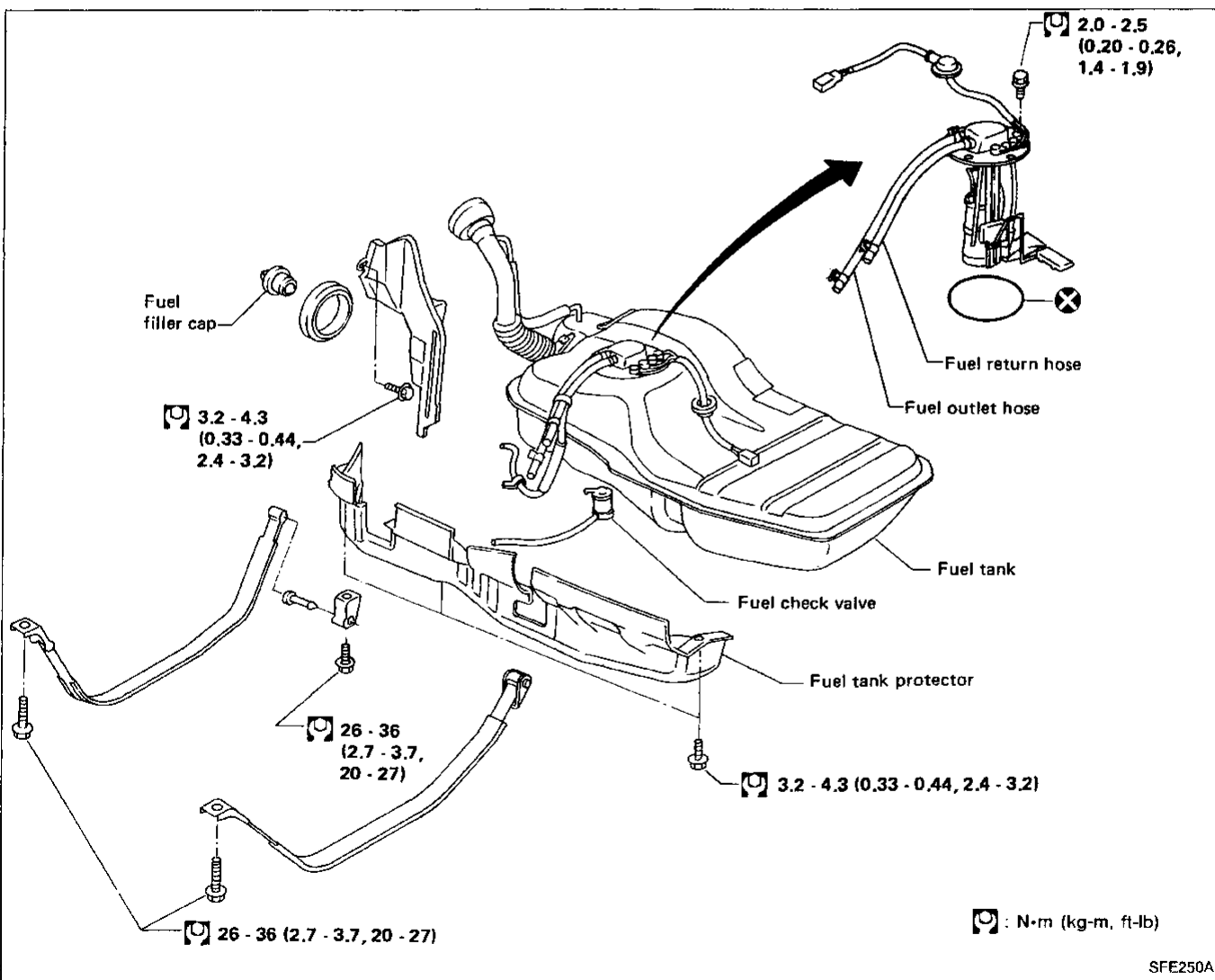

GI  
MA  
EM  
LC  
EF & EC  
FE  
CL  
MT  
AT  
PD  
FA  
RA  
BR  
ST  
BF  
HA  
EL

# EXHAUST SYSTEM

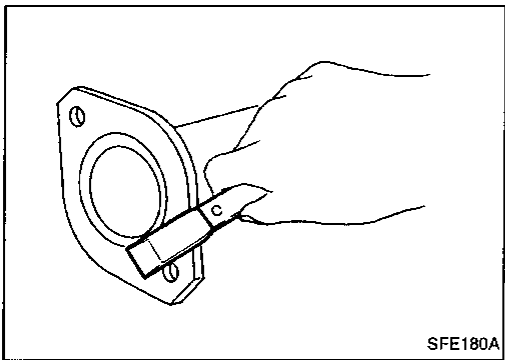

## CAUTION:

- Always replace exhaust gaskets with new ones when reassembling. If gasket is left on flange surface, scrape off completely as shown at left.
- With engine running, check all tube connections for exhaust gas leaks, and entire system for unusual noises.
- After installation, check to ensure that mounting brackets and mounting insulator are free from undue stress. If any of the above parts are not installed properly, excessive noise or vibration may be transmitted to the vehicle body.

