

ENGINE LUBRICATION & COOLING SYSTEMS

SECTION **LC**

GI

MA

EM

LC

EC

FE

CL

MT

AT

PD

FA

RA

BR

ST

BF

HA

EL

IDX

CONTENTS

PRECAUTION AND PREPARATION	2	System Check.....	6
Precaution	2	Water Pump.....	7
Special Service Tools	2	Thermostat	8
ENGINE LUBRICATION SYSTEM	3	Radiator	9
Lubrication Circuit.....	3	Cooling Fan	9
Oil Pressure Check.....	3	SERVICE DATA AND SPECIFICATIONS (SDS)	10
Oil Pump.....	4	Engine Lubrication System.....	10
ENGINE COOLING SYSTEM	6	Engine Cooling System	10
Cooling Circuit	6		

PRECAUTION AND PREPARATION

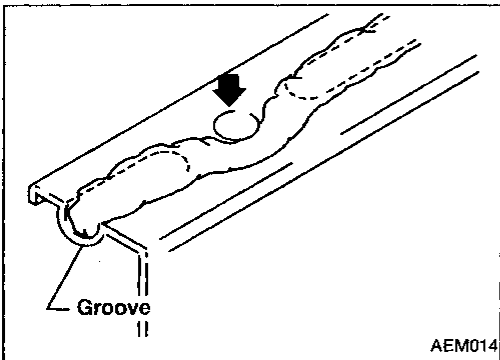
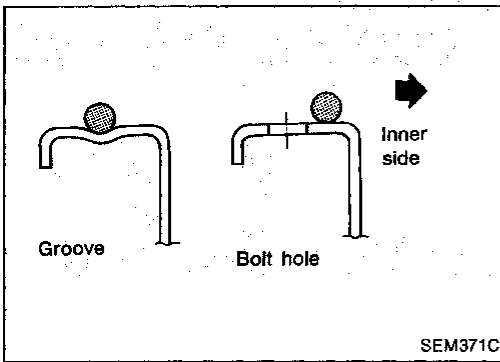

Precaution

LIQUID GASKET APPLICATION PROCEDURE

- Remove all traces of old liquid gasket from mating surfaces and grooves using a scraper. Then completely clean any oil stains from these portions.
- Apply a continuous bead of liquid gasket to mating surfaces. (Use Genuine Liquid Gasket or equivalent.)
 - Be sure liquid gasket is 3.5 to 4.5 mm (0.138 to 0.177 in) wide (for oil pan).
 - Be sure liquid gasket is 2.0 to 3.0 mm (0.079 to 0.118 in) wide (in areas except oil pan).
- Apply liquid gasket to inner surface around hole perimeter area. (Assembly should be done within 5 minutes after coating.)
- Wait at least 30 minutes before refilling engine oil and engine coolant.

Special Service Tools

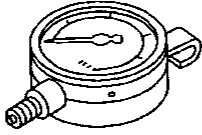
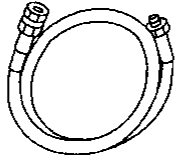
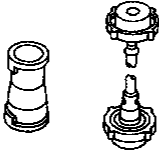
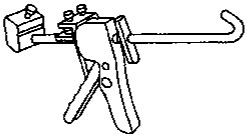
Tool number (Kent-Moore No.) Tool name	Description
ST25051001 (J25695-1) Oil pressure gauge	 <p>NT050</p>
ST25052000 (J25695-2) Hose	 <p>Adapting oil pressure gauge to cylinder block</p> <p>NT051</p>
EG17650301 (—) Radiator cap tester adapter	 <p>Adapting radiator cap tester to radiator filler neck</p> <p>NT053</p>
WS39930000 (—) Tube presser	 <p>Pressing the tube of liquid gasket</p> <p>NT052</p>

Lubrication Circuit

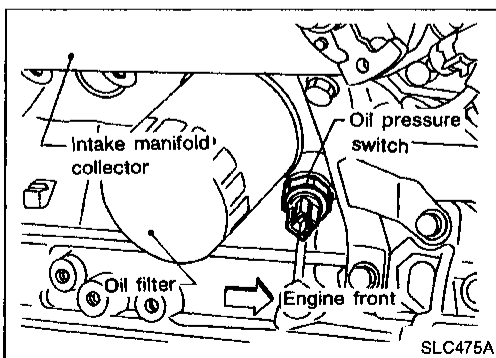
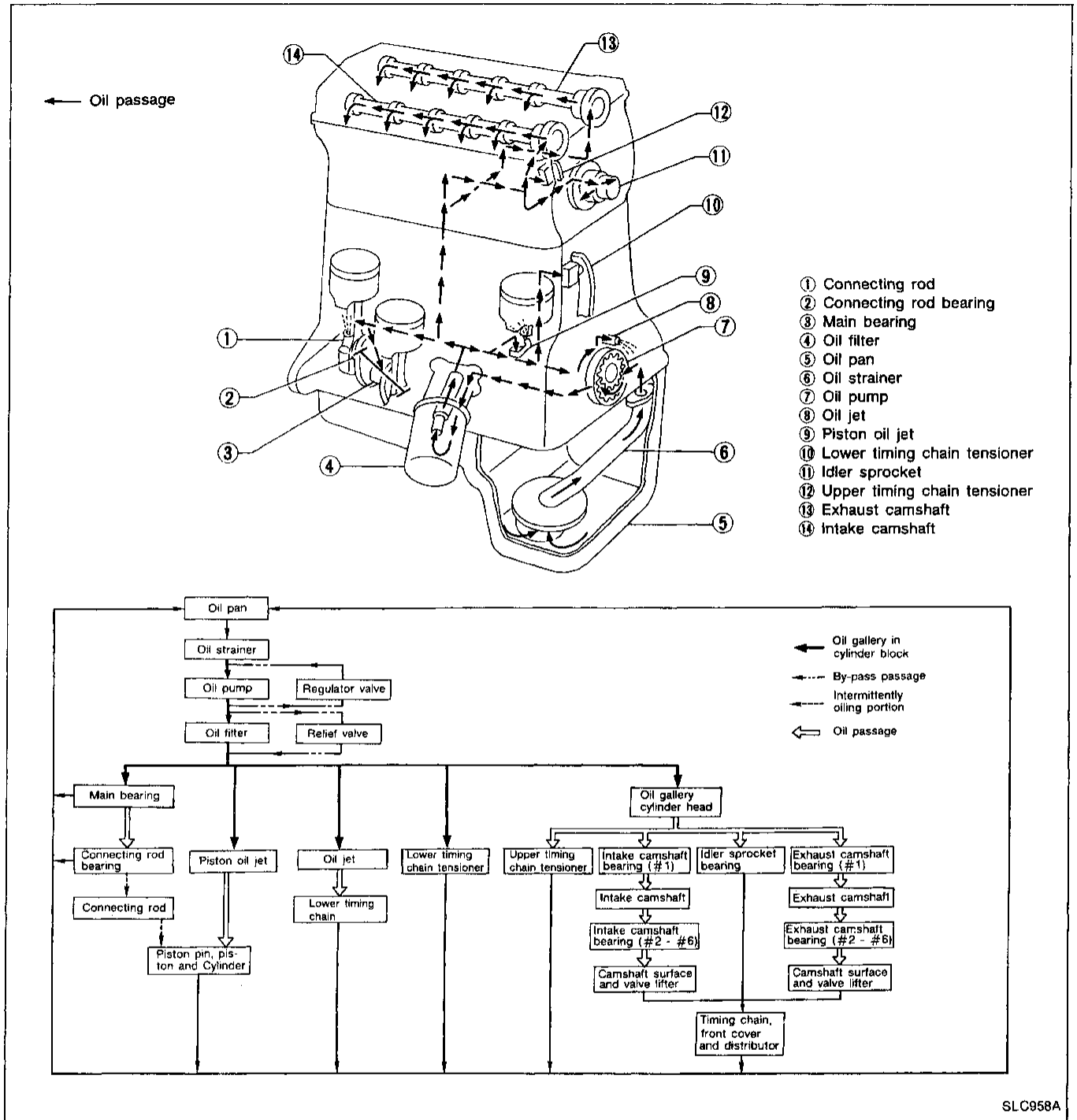

Oil Pressure Check

WARNING:

- Be careful not to burn yourself, as the engine and oil may hot.
 - Oil pressure check should be done in "Neutral position".
1. Check oil level.
 2. Remove oil pressure switch.

ENGINE LUBRICATION SYSTEM

Oil Pressure Check (Cont'd)

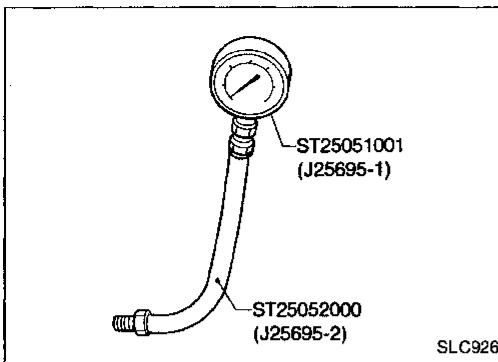

3. Install pressure gauge.
4. Start engine and warm it up to normal operating temperature.
5. Check oil pressure with engine running under no-load.

Approximate discharge pressure: kPa (kg/cm², psi)

Engine speed at idle

More than 78 (0.8, 11)

Engine speed at 3,000 rpm

412 - 481 (4.2 - 4.9, 60 - 70)

If difference is extreme, check oil passage and oil pump for oil leaks.

6. Install oil pressure switch with sealant.

Oil Pump

REMOVAL

1. Remove front cover.

Refer to "TIMING CHAIN" in EM section.

2. Remove oil pump cover.

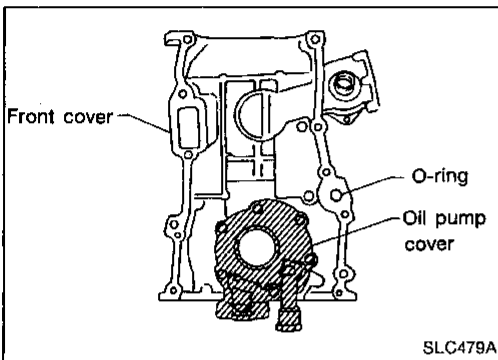

SEC. 135-150

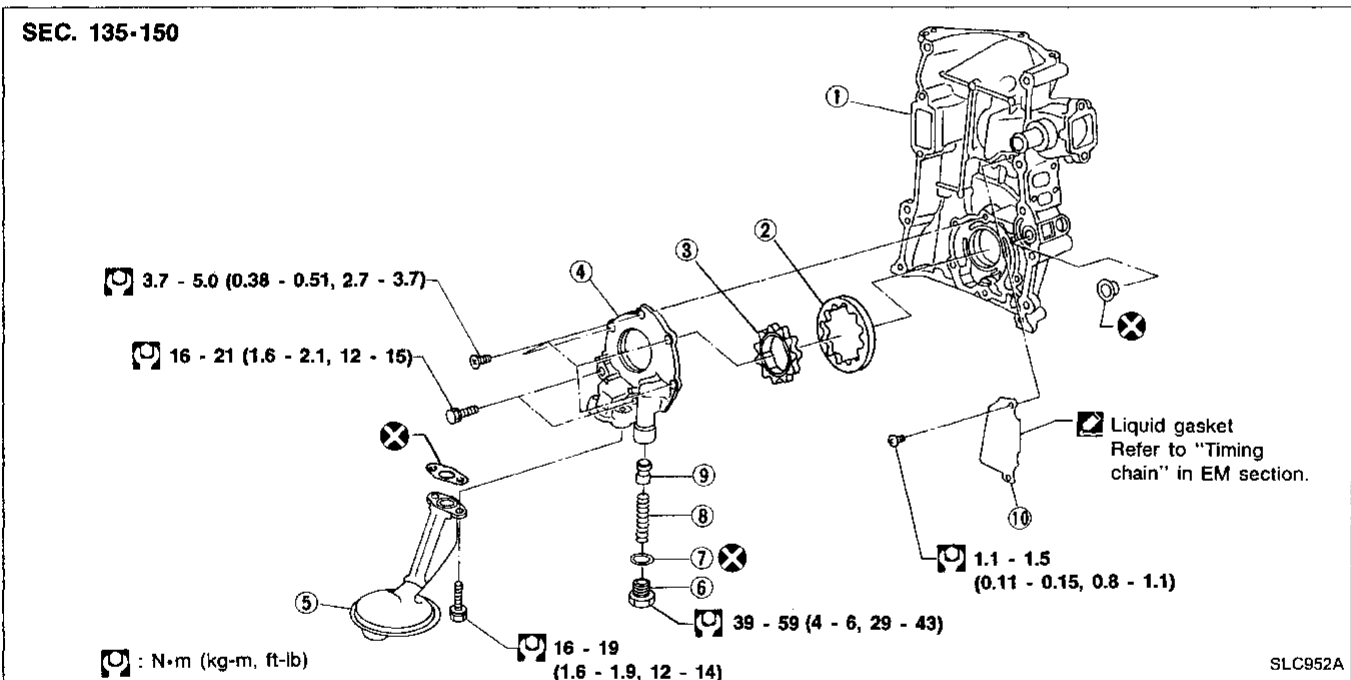

- | | |
|------------------|-----------------------|
| ① Front cover | ⑥ Cap |
| ② Outer gear | ⑦ Washer |
| ③ Inner gear | ⑧ Spring |
| ④ Oil pump cover | ⑨ Regulator valve |
| ⑤ Oil strainer | ⑩ Oil separator cover |

- Always replace oil seals and gaskets with new ones.
- When installing oil pump, apply engine oil to inner and outer gears.

ENGINE LUBRICATION SYSTEM

Oil Pump (Cont'd)

REGULATOR VALVE INSPECTION

1. Visually inspect components for wear and damage.
2. Check oil pressure regulator valve sliding surface and valve spring.
3. Coat regulator valve with engine oil. Check that it falls smoothly into the valve hole by its own weight.

If damaged, replace regulator valve set or oil pump assembly.

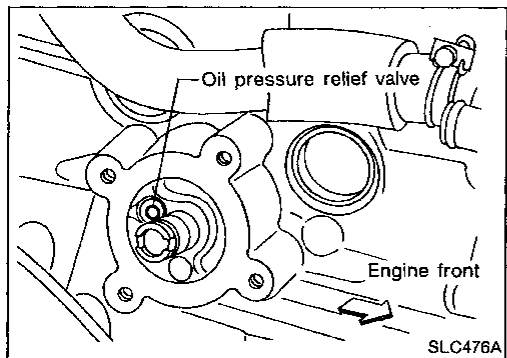
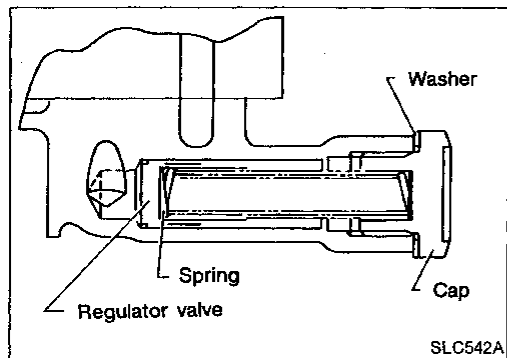

OIL PRESSURE RELIEF VALVE INSPECTION

Inspect oil pressure relief valve for movement, cracks and breaks by pushing the ball. If replacement is necessary, remove valve by prying it out with a suitable tool. Install a new valve in place by tapping it.

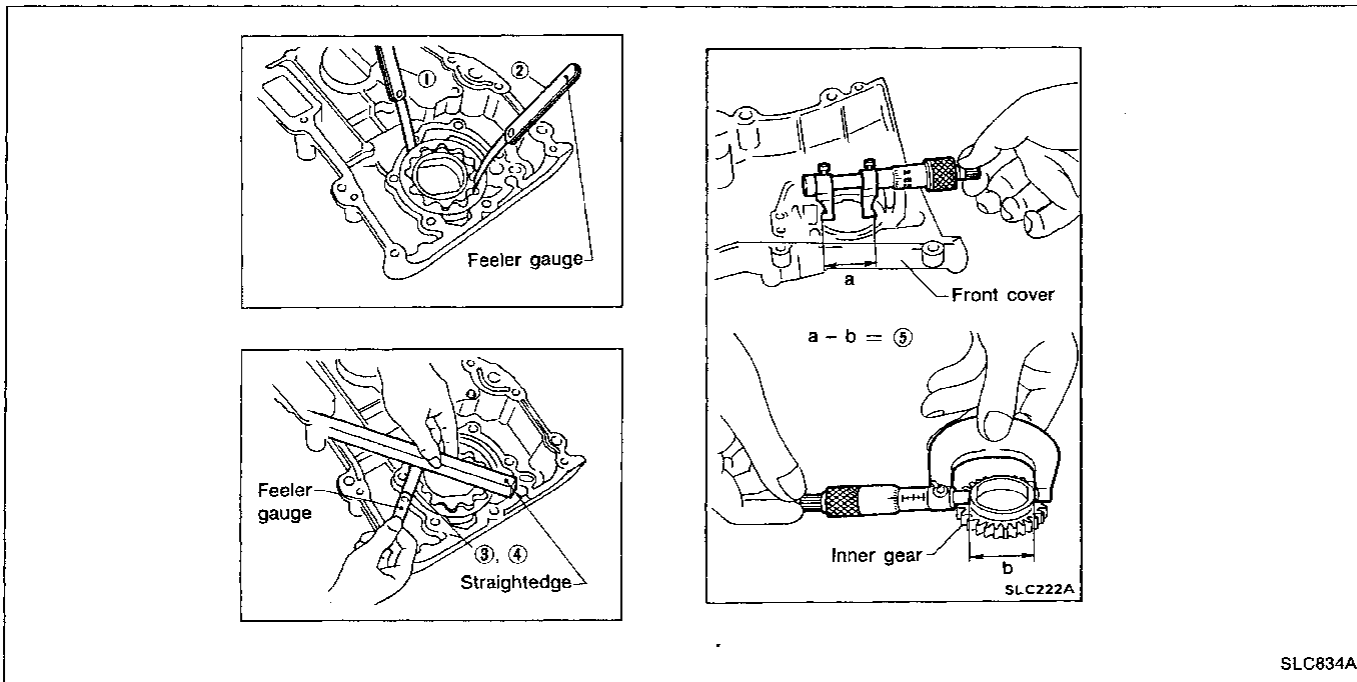

OIL PUMP INSPECTION

Using a feeler gauge, check the following clearances.

Standard clearance:	Unit: mm (in)
Body to outer gear clearance ①	0.114 - 0.200 (0.0045 - 0.0079)
Inner gear to outer gear tip clearance ②	0.04 - 0.18 (0.0016 - 0.0071)
Cover to inner gear clearance ③	0.05 - 0.09 (0.0020 - 0.0035)
Cover to outer gear clearance ④	0.05 - 0.11 (0.0020 - 0.0043)
Inner gear to brazed portion clearance ⑤	0.045 - 0.091 (0.0018 - 0.0036)

- If the tip clearance (②) exceeds the limit, replace gear set.
- If body to gear clearances (①, ③, ④, ⑤) exceed the limit, replace front cover assembly.

ENGINE COOLING SYSTEM

Cooling Circuit

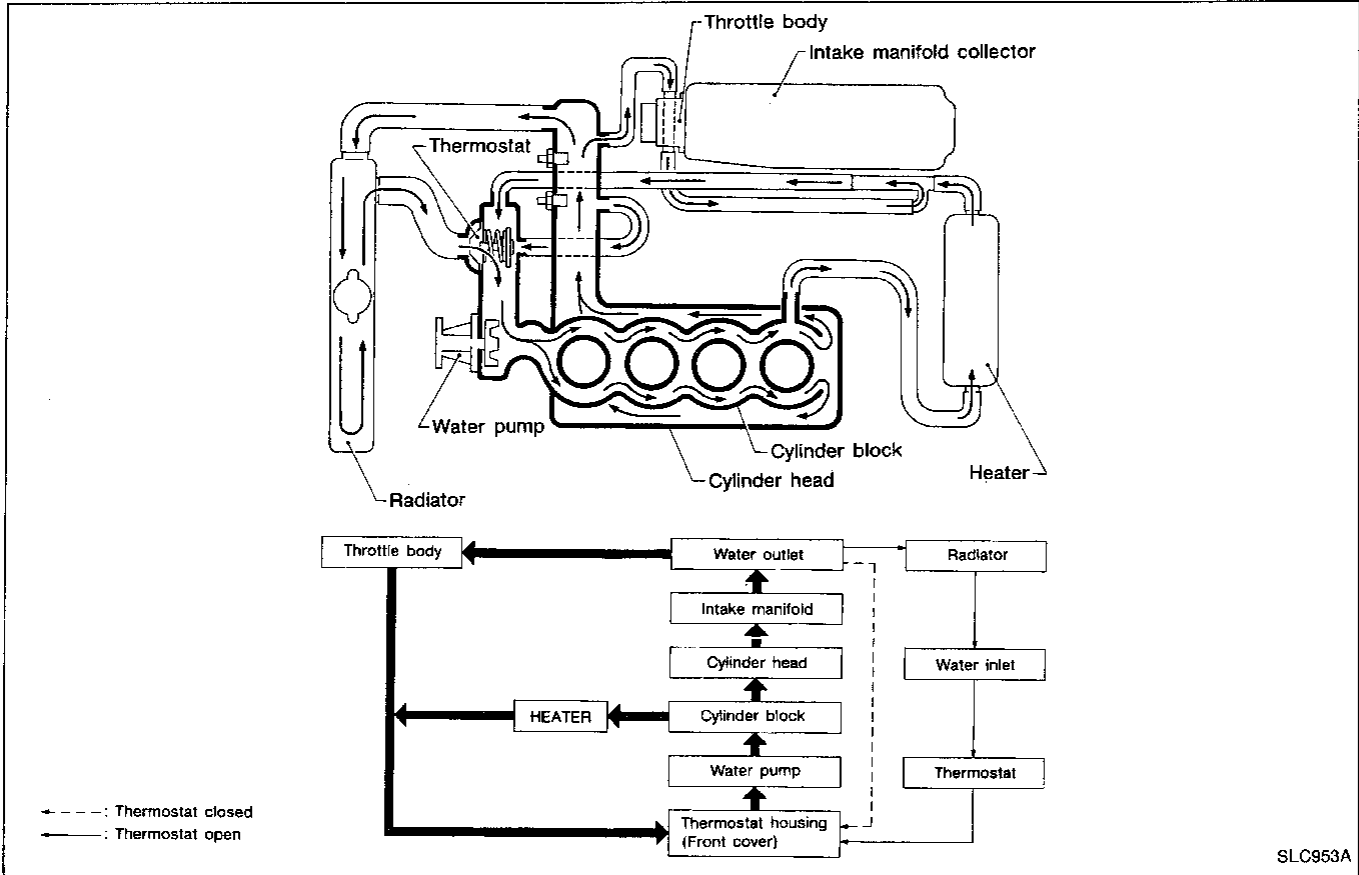

System Check

WARNING:

Never remove the radiator cap when the engine is hot; serious burns could be caused by high pressure fluid escaping from the radiator.

Wrap a thick cloth around cap and carefully remove the cap by turning it a quarter turn to allow built-up pressure to escape and then turn the cap all the way off.

CHECKING COOLING SYSTEM HOSES

Check hoses for improper attachment, leaks, cracks, damage, loose connections, chafing and deterioration.

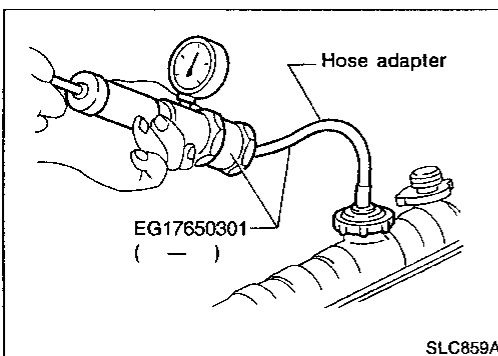

CHECKING COOLING SYSTEM FOR LEAKS

To check for leakage, apply pressure to the cooling system with a tester.

Testing pressure:

157 kPa (1.6 kg/cm², 23 psi)

CAUTION:

Higher than the specified pressure may cause radiator damage.

ENGINE COOLING SYSTEM

System Check (Cont'd)

CHECKING RADIATOR CAP

To check radiator cap, apply pressure to cap with a tester.

Radiator cap relief pressure:

78 - 98 kPa (0.8 - 1.0 kg/cm², 11 - 14 psi)

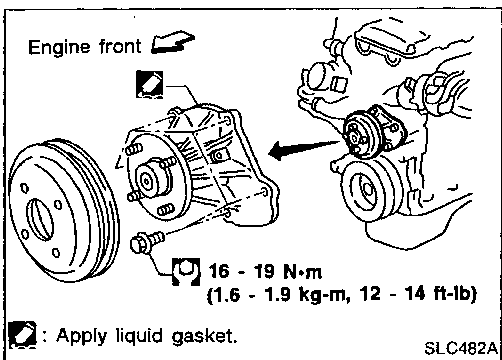
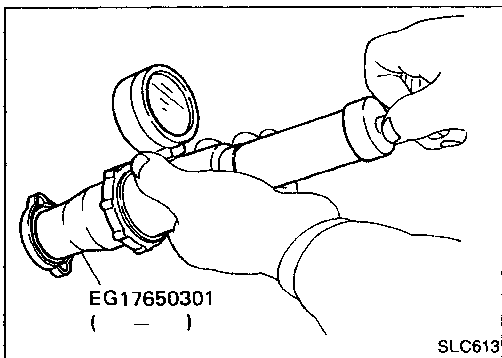

Water Pump

CAUTION:

- When removing water pump assembly, be careful not to get coolant on drive belt.
- Water pump cannot be disassembled and should be replaced as a unit.
- After installing water pump, connect hose and clamp securely, then check for leaks using radiator cap tester.

REMOVAL

1. Drain coolant from cylinder block and radiator.
2. Remove fan coupling with fan.
3. Remove power steering pump drive belt, alternator drive belt and air compressor drive belt.
4. Remove water pump.

INSPECTION

1. Check for badly rusted or corroded vanes and body assembly.
2. Check for rough operation due to excessive end play.

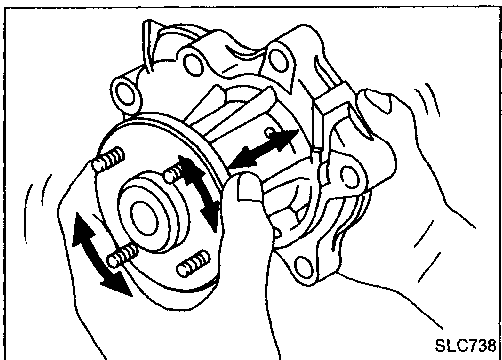

INSTALLATION

1. Before installing, remove all traces of liquid gasket from mating surface using a scraper.
- Also remove traces of liquid gasket from mating surface of cylinder block.

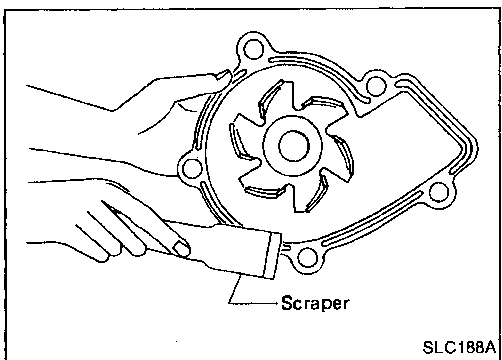

ENGINE COOLING SYSTEM

Water Pump (Cont'd)

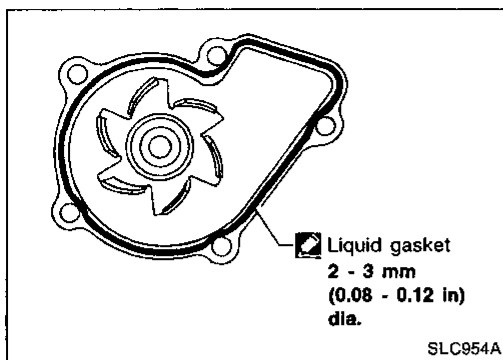

2. Apply a continuous bead of liquid gasket to mating surface of water pump.
 - Use genuine liquid gasket or equivalent.

Thermostat

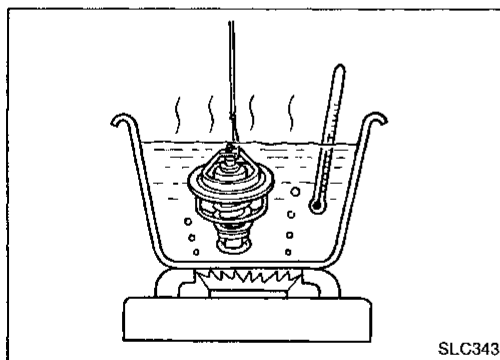
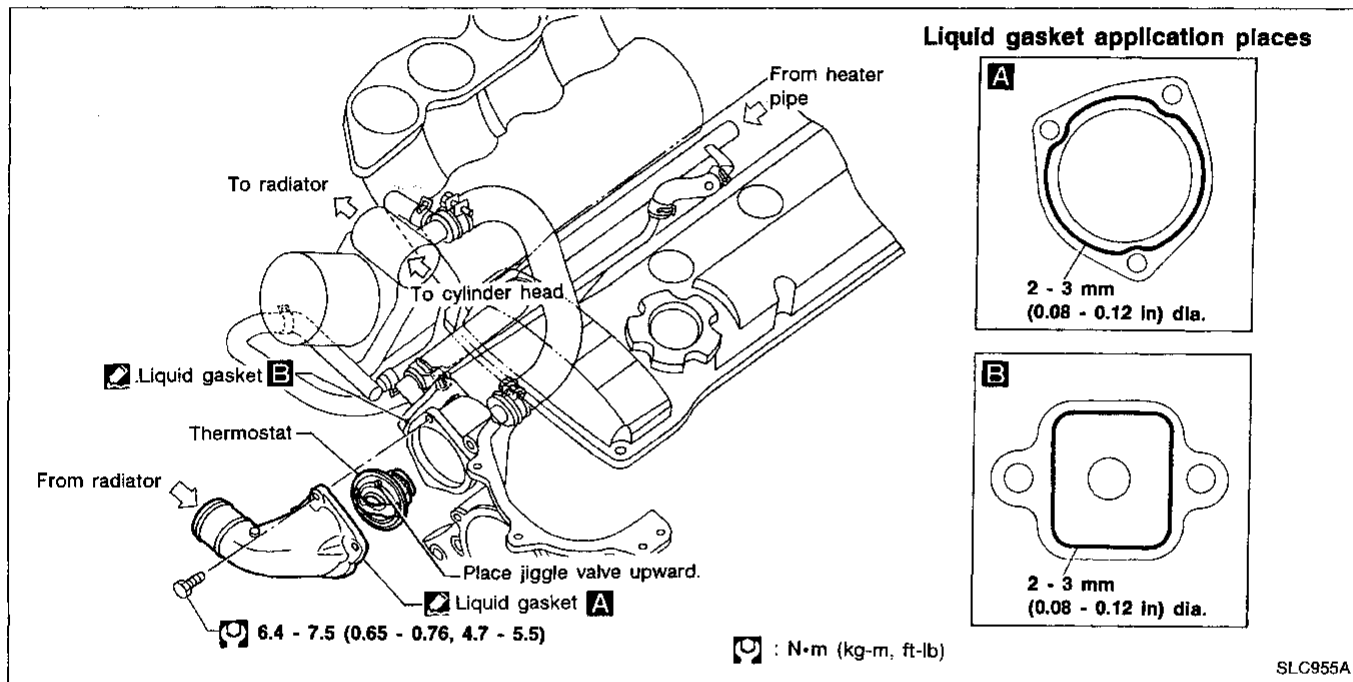

INSPECTION

1. Check valve seating condition at ordinary room temperatures. It should seat tightly.
2. Check valve opening temperature and maximum valve lift.

Valve opening temperature	°C (°F)	76.5 (170)
Maximum valve lift	mm/°C (in/°F)	More than 10/90 (0.39/194)

3. Then check if valve is closed at 5°C (9°F) below valve opening temperature.
 - Apply a continuous bead of liquid gasket to mating surface of water inlet. Refer to "Water Pump (LC-7)".
 - After installation, run engine for a few minutes, and check for leaks.
 - Be careful not to spill coolant over engine compartment. Use a rag to absorb coolant.

Radiator

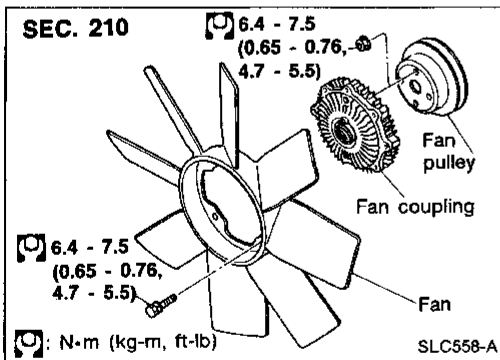
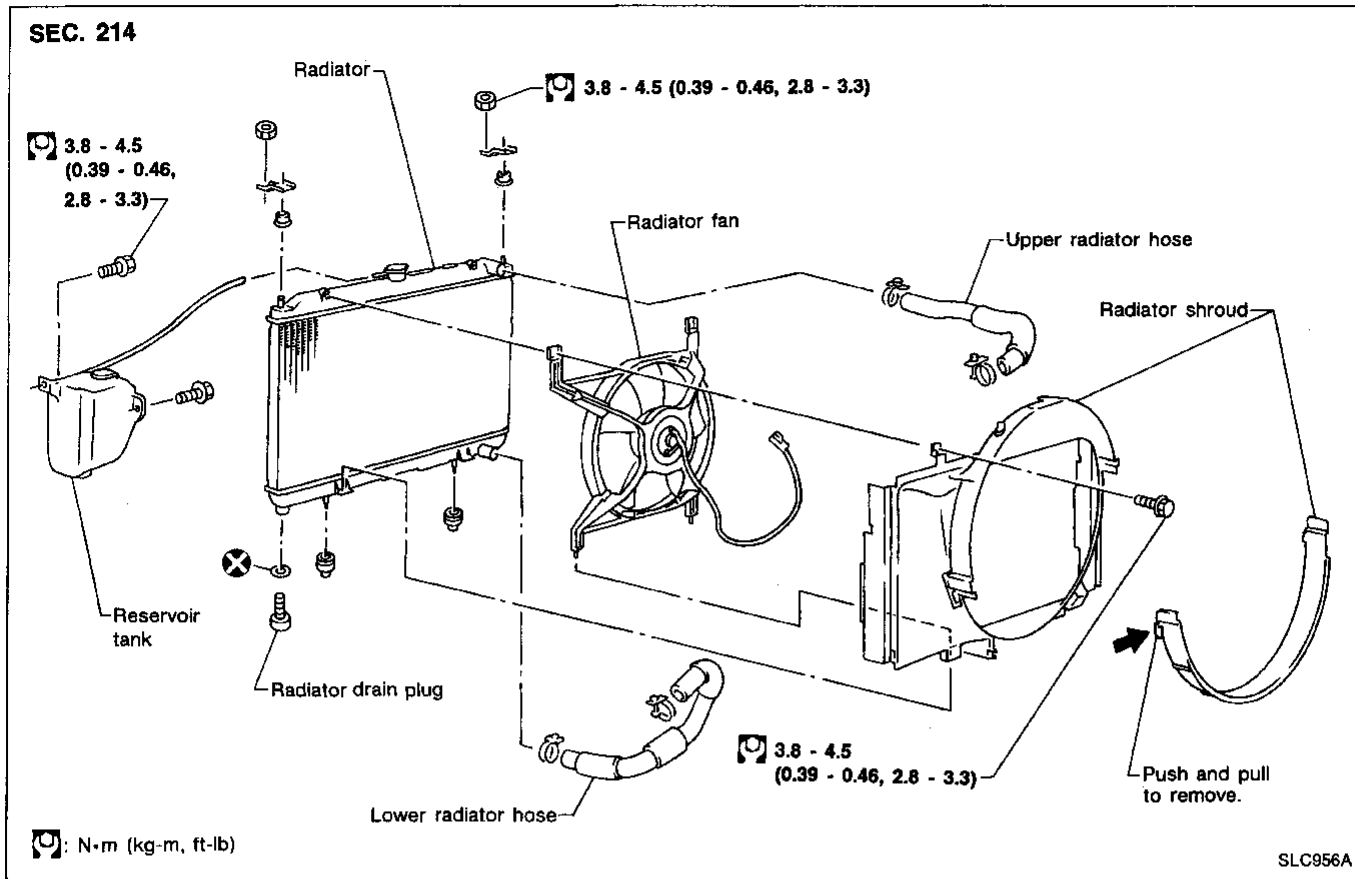

Cooling Fan

DISASSEMBLY AND ASSEMBLY

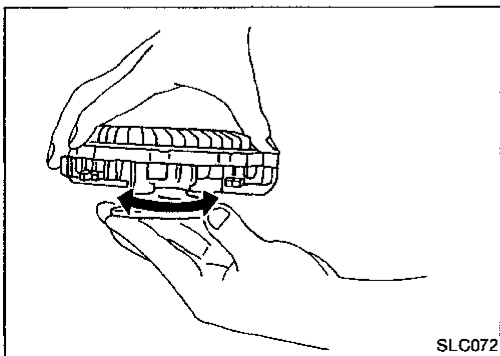

INSPECTION

Check fan coupling for rough operation, oil leakage or bent bimetal.

GI

MA

EM

LC

EC

FE

CL

MT

AT

PD

FA

RA

BR

ST

BF

HA

EL

IDX

SERVICE DATA AND SPECIFICATIONS (SDS)

Engine Lubrication System

Oil pressure check

Engine speed rpm	Approximate discharge pressure kPa (kg/cm ² , psi)
Idle speed	More than 78 (0.8, 11)
3,000	412 - 481 (4.2 - 4.9, 60 - 70)

Oil pump

		Unit: mm (in)
Body to outer gear clearance	0.114 - 0.200 (0.0045 - 0.0079)
Inner gear to outer gear tip clearance	0.04 - 0.18 (0.0016 - 0.0071)
Cover to inner gear clearance	0.05 - 0.09 (0.0020 - 0.0035)
Cover to outer gear clearance	0.05 - 0.11 (0.0020 - 0.0043)
Inner gear to brazed portion clearance	0.045 - 0.091 (0.0018 - 0.0036)

Engine Cooling System

Thermostat

Valve opening temperature	°C (°F)	76.5 (170)
Max. valve lift	mm/°C (in/°F)	More than 10/90 (0.39/194)

Radiator

		Unit: kPa (kg/cm ² , psi)
Cap relief pressure		78 - 98 (0.8 - 1.0, 11 - 14)
Leakage test pressure		157 (1.6, 23)