

ENGINE LUBRICATION & COOLING SYSTEMS

SECTION LC

CI

WA

EM

LC

EC

FE

CL

MT

AT

PD

FA

RA

BR

ST

RS

BT

HA

EL

IDX

CONTENTS

PRECAUTION AND PREPARATION2	Water Pump.....8
Liquid Gasket Application Procedure2	Thermostat.....9
Special Service Tools2	Radiator10
ENGINE LUBRICATION SYSTEM4	Cooling Fan (Crankshaft driven)13
Lubrication Circuit.....4	Cooling Fan Control System13
Oil Pressure Check.....4	Overheating Cause Analysis14
Oil Pump.....5	SERVICE DATA AND SPECIFICATIONS (SDS)15
ENGINE COOLING SYSTEM7	Engine Lubrication System.....15
Cooling Circuit7	Engine Cooling System15
System Check.....7	

PRECAUTION AND PREPARATION

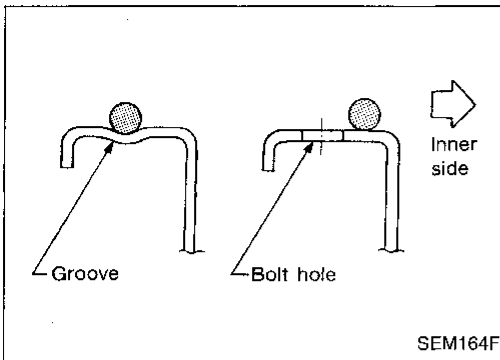

Liquid Gasket Application Procedure

- Use a scraper to remove all traces of old liquid gasket from mating surfaces and grooves. Also, completely clean any oil from these areas.
- Apply a continuous bead of liquid gasket to mating surfaces. (Use Genuine Liquid Gasket or equivalent.)
 - Be sure liquid gasket is 3.5 to 4.5 mm (0.138 to 0.177 in) wide (for oil pan).
 - Be sure liquid gasket is 2.0 to 3.0 mm (0.079 to 0.118 in) wide (in areas except oil pan).
- Apply liquid gasket around the inner side of bolt holes (unless otherwise specified).
- Assembly should be done within 5 minutes after coating.
- Wait at least 30 minutes before refilling engine oil and engine coolant.

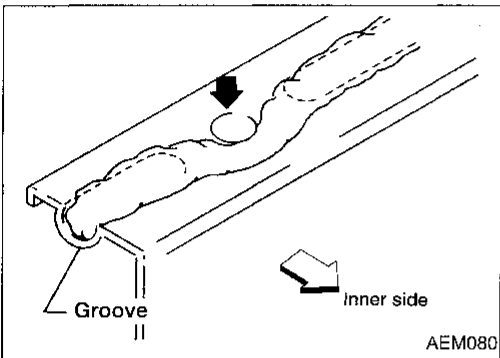

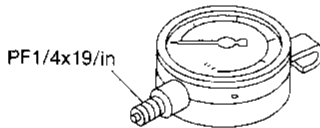
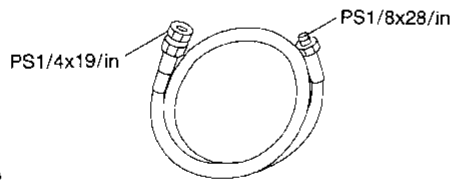
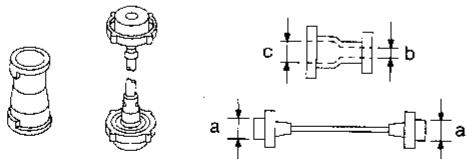
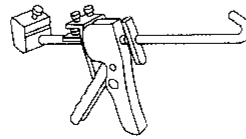

Special Service Tools

The actual shapes of Kent-Moore tools may differ from those of special service tools illustrated here.

Tool number (Kent-Moore No.) Tool name	Description
ST25051001 (J25695-1) Oil pressure gauge	 <p>Measuring oil pressure</p> <p>NT558</p> <p>Maximum measuring range: 2,452 kPa (25 kg/cm², 356 psi)</p>
ST25052000 (J25695-2) Hose	 <p>Adapting oil pressure gauge to cylinder block</p> <p>NT559</p>
EG17650301 (J33984-A) Radiator cap tester adapter	 <p>Adapting radiator cap tester to radiator filler neck</p> <p>NT564</p> <p>a: 28 (1.10) dia. b: 31.4 (1.236) dia. c: 41.3 (1.626) dia. Unit: mm (in)</p>
WS39930000 () Tube presser	 <p>Pressing the tube of liquid gasket</p> <p>NT052</p>

PRECAUTION AND PREPARATION

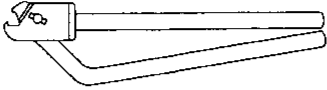
Special Service Tools (Cont'd)

Tool number (Kent-Moore No.) Tool name	Description	
KV99103510 (—) Radiator plate pliers A		Installing radiator upper and lower tanks GI MA EM
KV99103520 (—) Radiator plate pliers B		Removing radiator upper and lower tanks EM <div style="background-color: black; color: white; padding: 2px; display: inline-block;">LC</div> EC

- GI
- MA
- EM
- LC
- EC
- FE
- CL
- MT
- AT
- PD
- FA
- RA
- BR
- ST
- RS
- BT
- HA
- EL
- IDX

ENGINE LUBRICATION SYSTEM

Lubrication Circuit

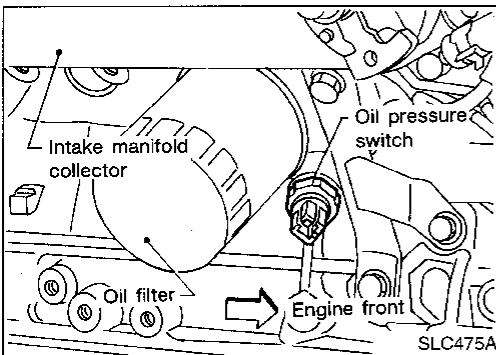
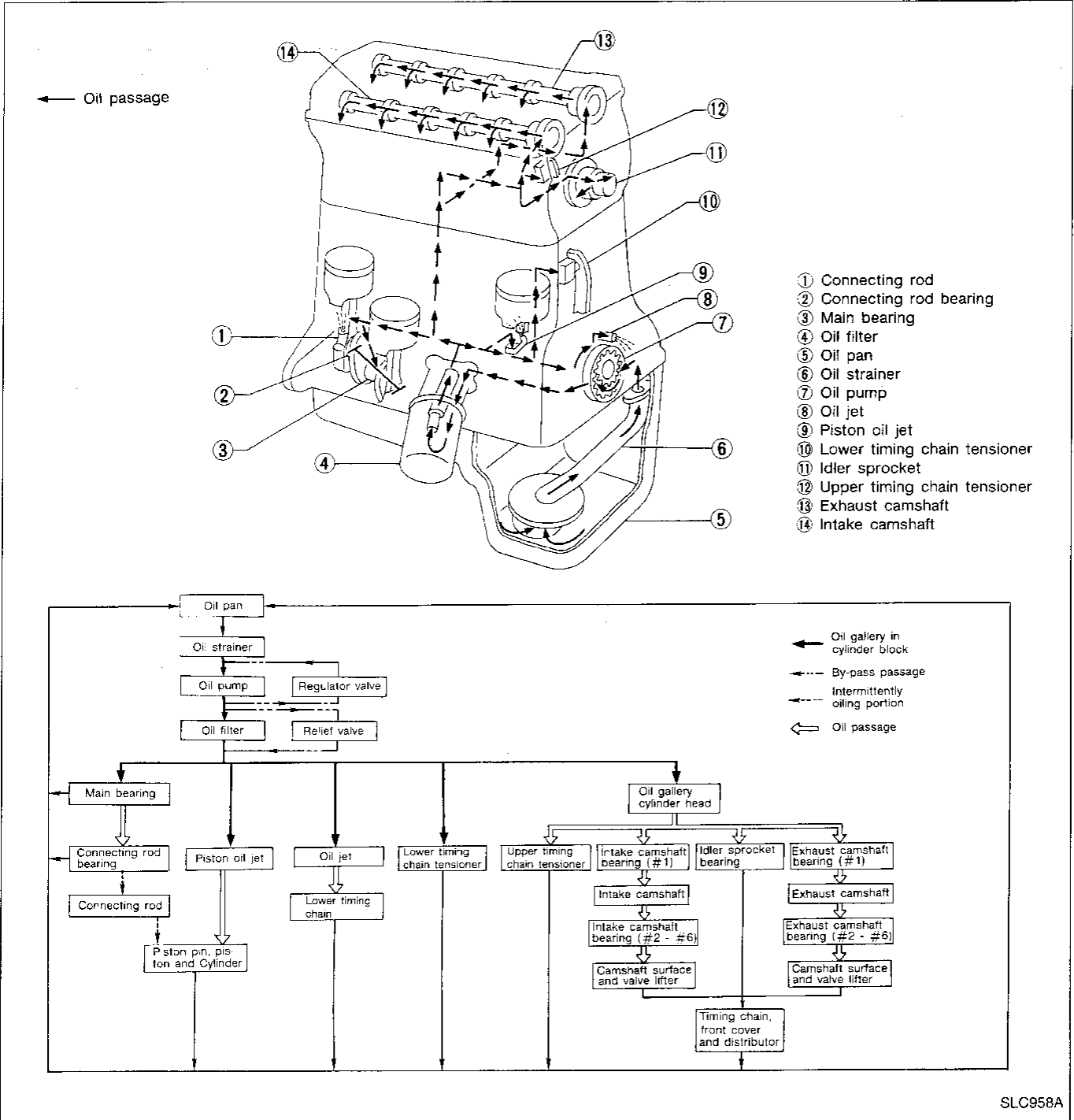

Oil Pressure Check

WARNING:

- Be careful not to burn yourself, as the engine and oil may be hot.
 - Oil pressure check should be done in "Neutral position".
1. Check oil level.
 2. Remove oil pressure switch.

ENGINE LUBRICATION SYSTEM

Oil Pressure Check (Cont'd)

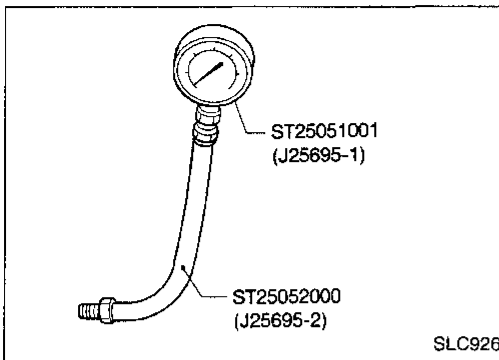

3. Install pressure gauge.
4. Start engine and warm it up to normal operating temperature.
5. Check oil pressure with engine running under no-load.

Approximate discharge pressure: kPa (kg/cm², psi)

Engine speed at idle

More than 78 (0.8, 11)

Engine speed at 3,000 rpm

412 - 481 (4.2 - 4.9, 60 - 70)

If difference is extreme, check oil passage and oil pump for oil leaks.

6. Install oil pressure switch with sealant.

CI

MA

EM

Oil Pump

REMOVAL

1. Remove front cover.

Refer to EM section ("TIMING CHAIN").

2. Remove oil pump cover.

LC

EC

FE

CL

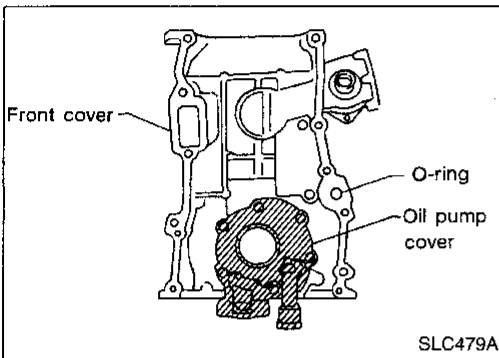

MT

AT

PD

FA

RA

BR

ST

RS

BT

HA

EL

IDX

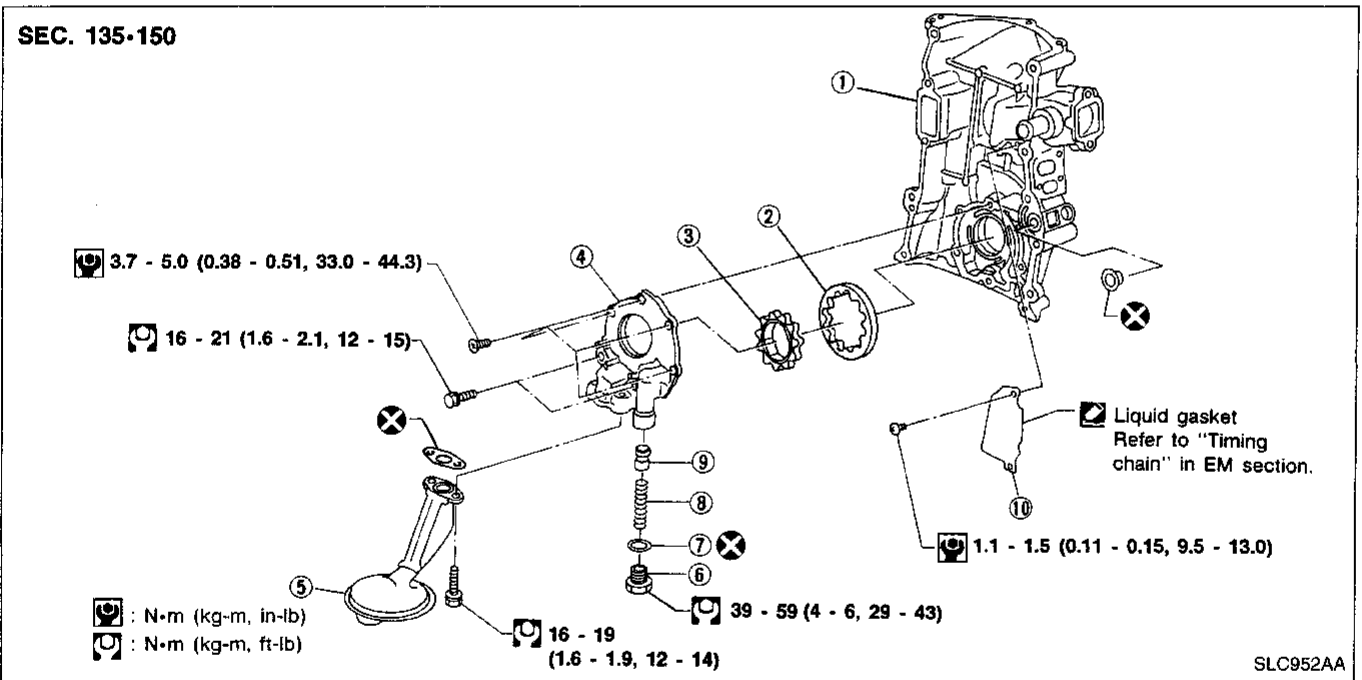

SLC952AA

- 1 Front cover
- 2 Outer gear
- 3 Inner gear
- 4 Oil pump cover

- 5 Oil strainer
- 6 Cap
- 7 Washer

- 8 Spring
- 9 Regulator valve
- 10 Oil separator cover

- Always replace oil seals and gaskets with new ones.
- When installing oil pump, apply engine oil to inner and outer gears.

ENGINE LUBRICATION SYSTEM

Oil Pump (Cont'd)

REGULATOR VALVE INSPECTION

1. Visually inspect components for wear and damage.
 2. Check oil pressure regulator valve sliding surface and valve spring.
 3. Coat regulator valve with engine oil. Check that it falls smoothly into the valve hole by its own weight.
- If damaged, replace regulator valve set or oil pump assembly.

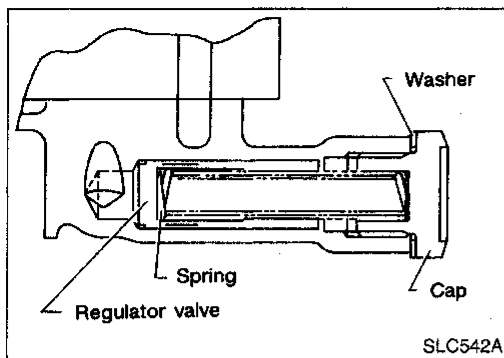

SLC542A

OIL PRESSURE RELIEF VALVE INSPECTION

Inspect oil pressure relief valve for movement, cracks and breaks by pushing the ball. If replacement is necessary, remove valve by prying it out with a suitable tool. Install a new valve in place by tapping it in.

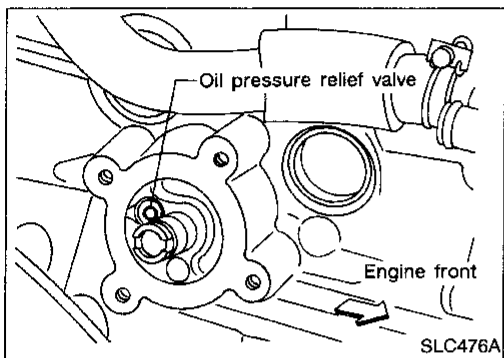

SLC476A

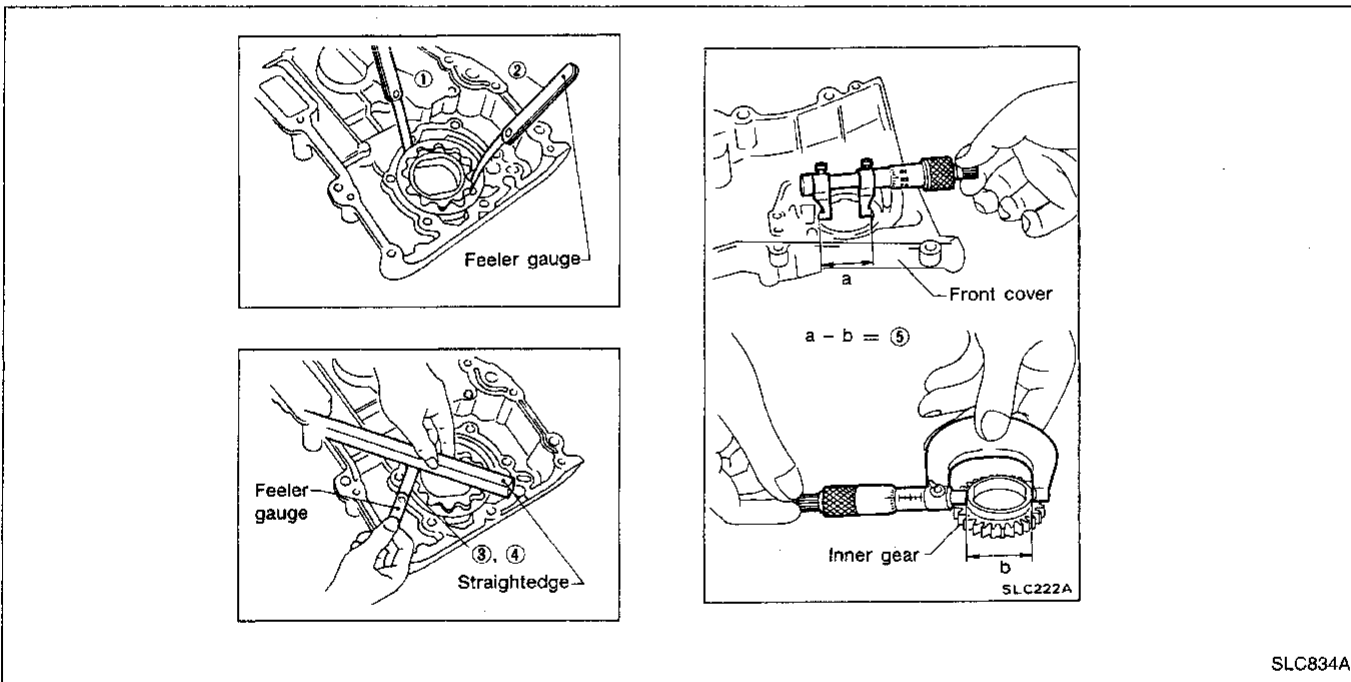

SLC834A

OIL PUMP INSPECTION

Using a feeler gauge, straightedge and micrometers, check the following clearances:

Unit: mm (in)

Body to outer gear clearance ①	0.114 - 0.200	(0.0045 - 0.0079)
Inner gear to outer gear tip clearance ②	0.04 - 0.18	(0.0016 - 0.0071)
Cover to inner gear clearance ③	0.05 - 0.09	(0.0020 - 0.0035)
Cover to outer gear clearance ④	0.05 - 0.11	(0.0020 - 0.0043)
Inner gear to brazed portion clearance ⑤	0.045 - 0.091	(0.0018 - 0.0036)

- If the tip clearance (②) exceeds the limit, replace gear set.
- If body to gear clearances (①, ③, ④, ⑤) exceed the limit, replace front cover assembly.

ENGINE COOLING SYSTEM

Cooling Circuit

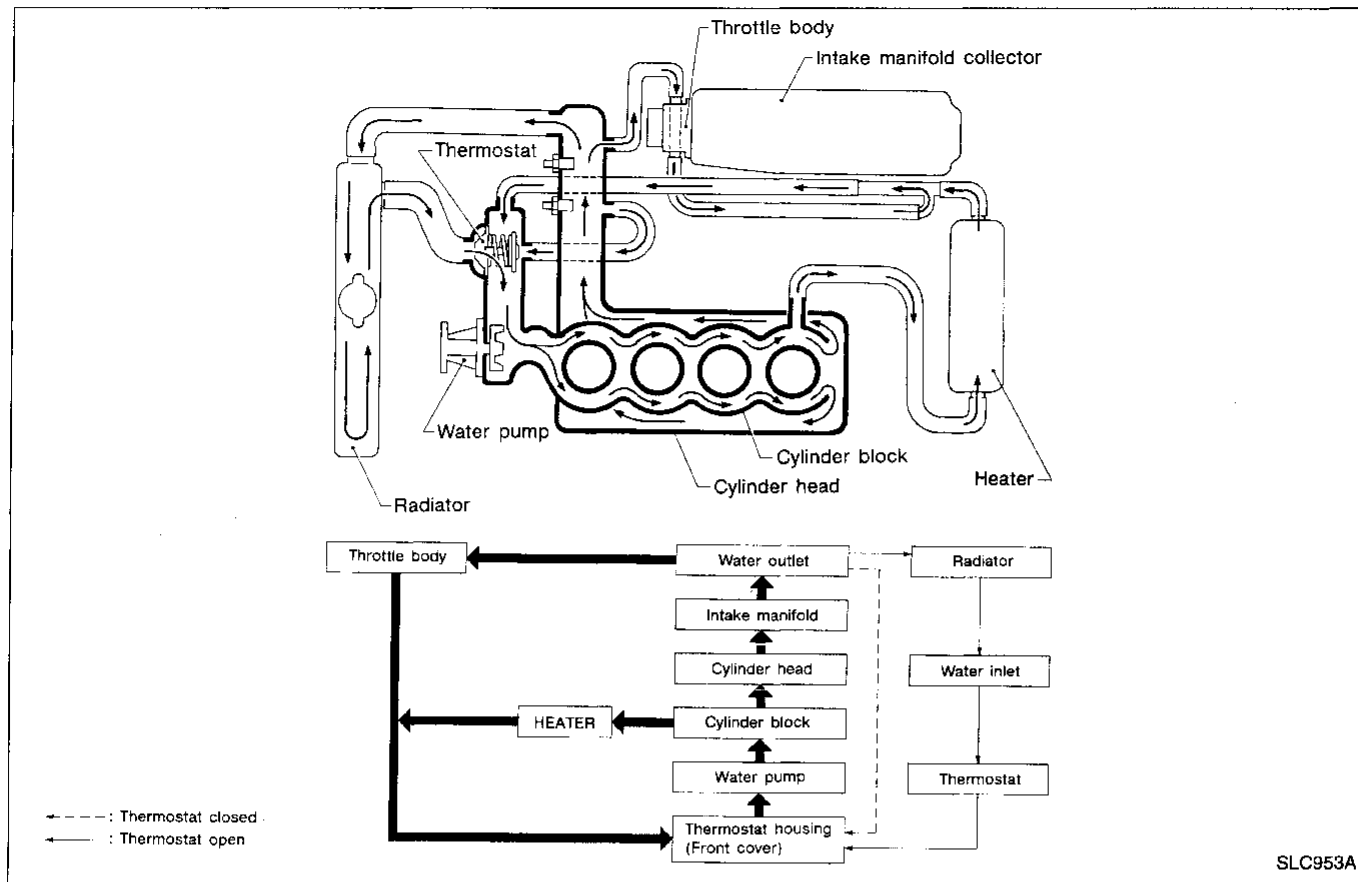

System Check

WARNING:

Never remove the radiator cap when the engine is hot; serious burns could be caused by high pressure fluid escaping from the radiator.

Wrap a thick cloth around cap and carefully remove the cap by turning it a quarter turn to allow built-up pressure to escape and then turn the cap all the way off.

CHECKING COOLING SYSTEM HOSES

Check hoses for improper attachment, leaks, cracks, damage, loose connections, chafing and deterioration.

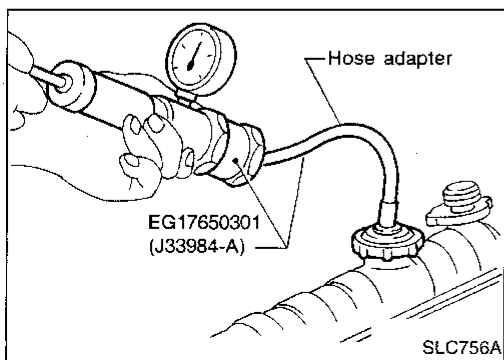

CHECKING COOLING SYSTEM FOR LEAKS

To check for leakage, apply pressure to the cooling system with a tester.

Testing pressure:
157 kPa (1.6 kg/cm², 23 psi)

CAUTION:

Higher than the specified pressure may cause radiator damage.

ENGINE COOLING SYSTEM

System Check (Cont'd)

CHECKING RADIATOR CAP

To check radiator cap, apply pressure to cap with a tester.

Radiator cap relief pressure:

Standard

78 - 98 kPa (0.8 - 1.0 kg/cm², 11 - 14 psi)

Limit

59 - 98 kPa (0.6 - 1.0 kg/cm², 9 - 14 psi)

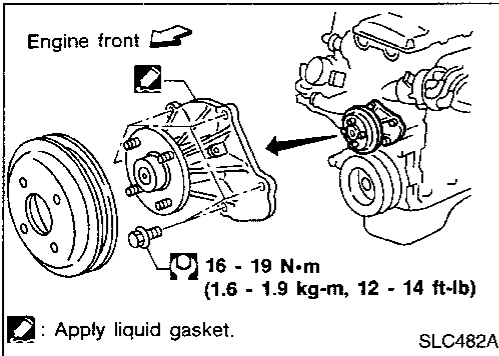
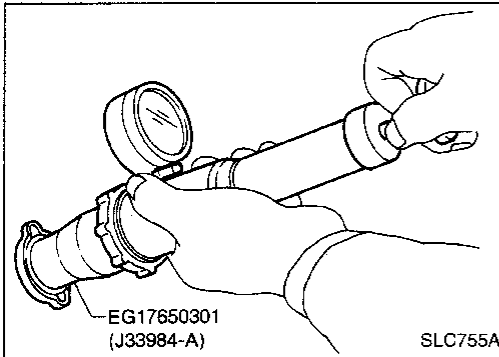

Water Pump

CAUTION:

- When removing water pump assembly, be careful not to get coolant on drive belt.
- Water pump cannot be disassembled and should be replaced as a unit.
- After installing water pump, connect hose and clamp securely, then check for leaks using radiator cap tester.

REMOVAL

1. Drain coolant from cylinder block and radiator. Refer to MA section ("Changing Engine Coolant").
2. Remove fan coupling with fan.
3. Remove power steering pump drive belt, alternator drive belt and air compressor drive belt.
4. Remove water pump.

INSPECTION

1. Check for badly rusted or corroded vanes and body assembly.
2. Check for rough operation due to excessive end play.

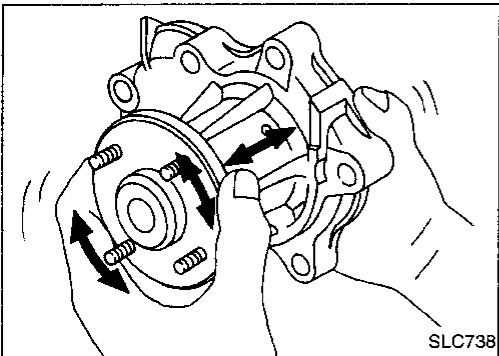

INSTALLATION

1. Before installing, remove all traces of liquid gasket from mating surface using a scraper.
- Also remove traces of liquid gasket from mating surface of front cover.

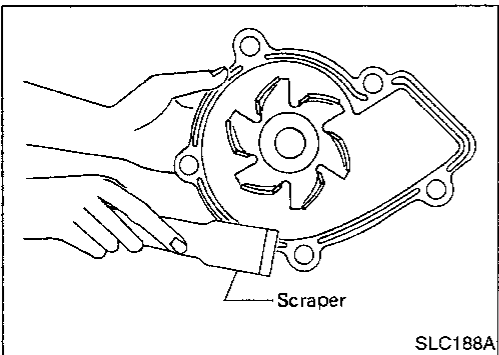

ENGINE COOLING SYSTEM

Water Pump (Cont'd)

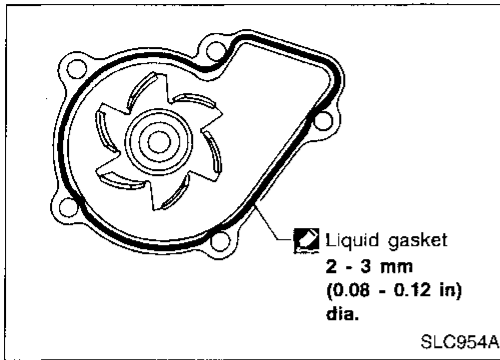

2. Apply a continuous bead of liquid gasket to mating surface of water pump.
 - Use genuine liquid gasket or equivalent.

Thermostat

SEC. 210

Liquid gasket application places

A

2 - 3 mm
(0.08 - 0.12 in) dia.

B

2 - 3 mm
(0.08 - 0.12 in) dia.

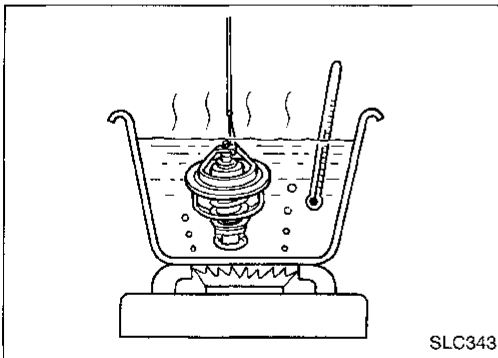

INSPECTION

1. Check valve seating condition at ordinary room temperatures. It should seat tightly.
2. Check valve opening temperature and maximum valve lift.

Valve opening temperature	°C (°F)	76.5 (170)
Valve lift	mm/°C (in/°F)	More than 10/90 (0.39/194)

3. Then check if valve is closed at 5°C (9°F) below valve opening temperature.

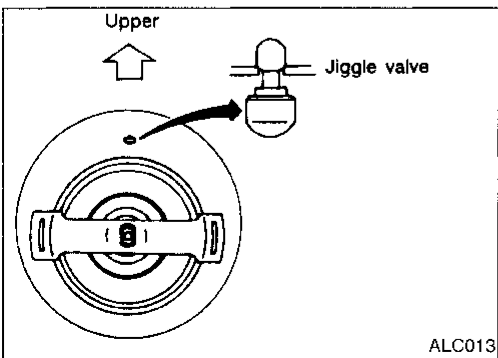

INSTALLATION

Install thermostat with jiggle valve at upper side.

- Apply a continuous bead of liquid gasket to mating surface of water inlet.
- After installation, run engine for a few minutes, and check for leaks.
- Be careful not to spill coolant over engine compartment. Use a rag to absorb coolant.

ENGINE COOLING SYSTEM

Radiator REMOVAL AND INSTALLATION

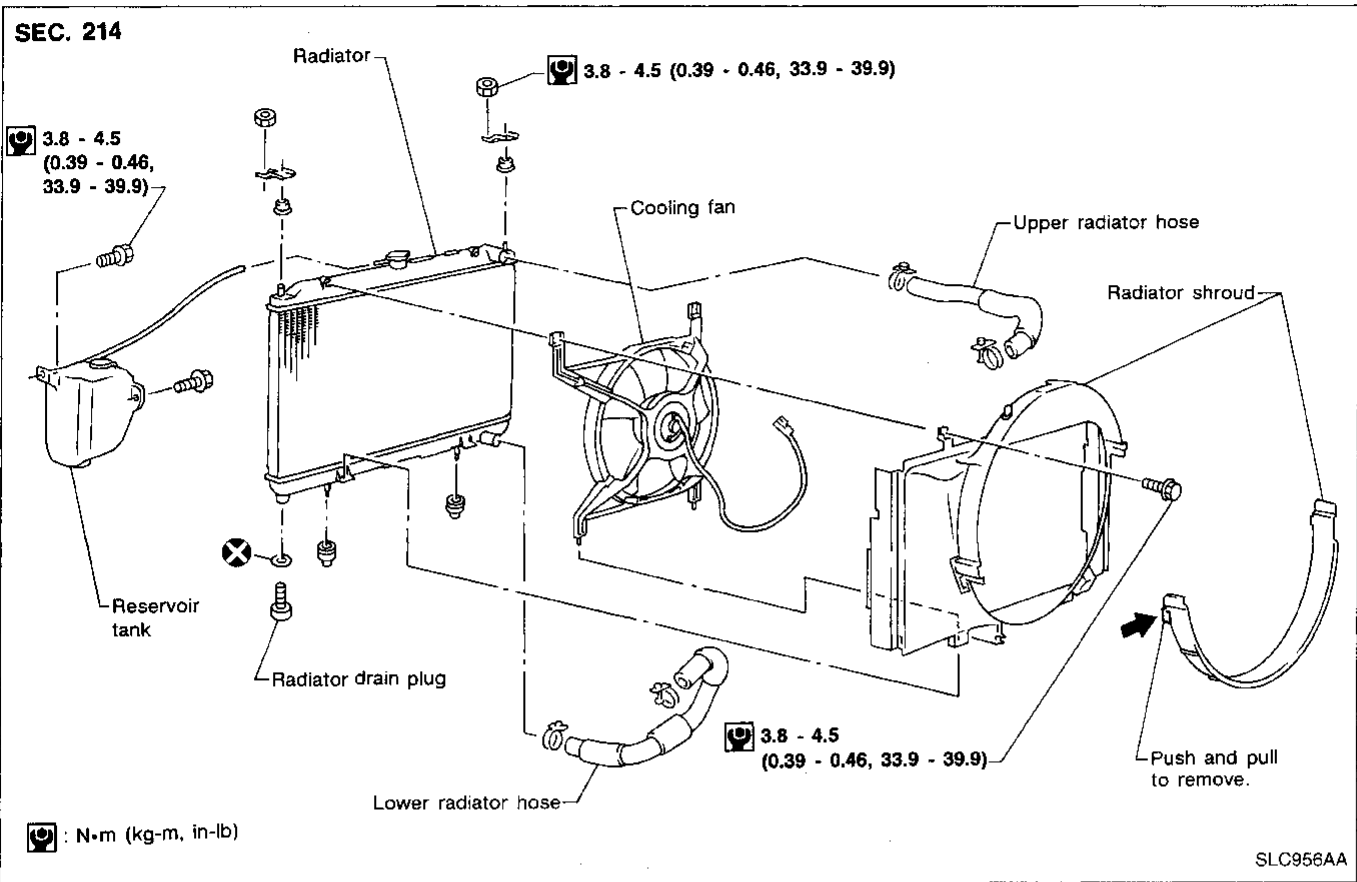

DISASSEMBLY AND ASSEMBLY

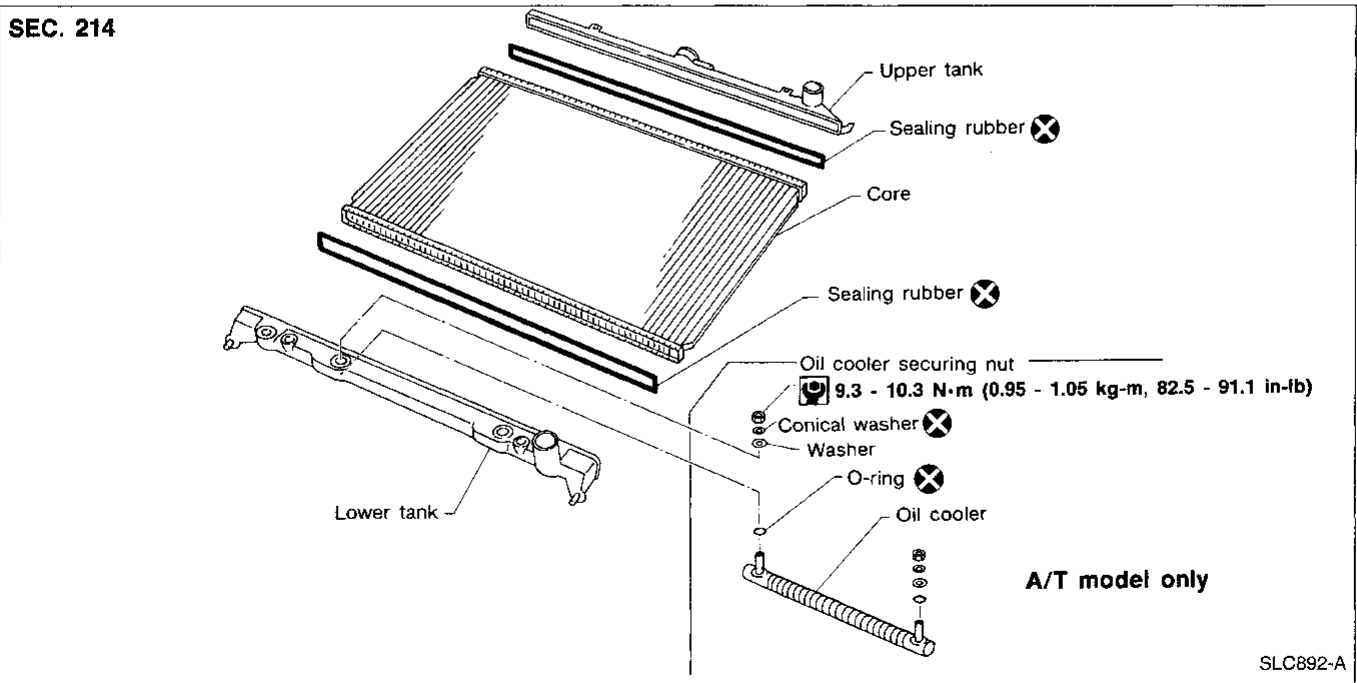

ENGINE COOLING SYSTEM

Radiator (Cont'd)

Preparation

1. Attach the spacer to the tip of the radiator plate pliers A. Spacer specification: 1.5 mm (0.059 in) thick x 18 mm (0.71 in) wide x 8.5 mm (0.335 in) long.
2. Make sure that when radiator plate pliers A are closed dimension H'' is approx. 7.6 mm (0.299 in).
3. Adjust dimension H'' with the spacer, if necessary.

GI

MA

EM

LC

EC

FE

CL

MT

AT

PD

FA

RA

BR

ST

RS

BT

HA

EL

IDX

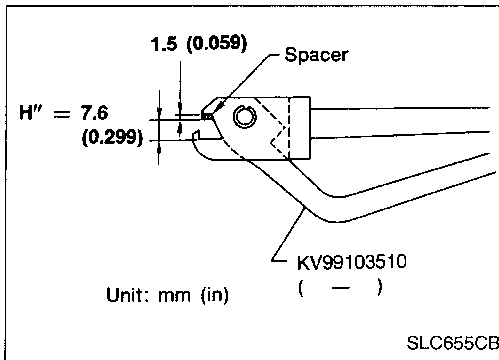

Disassembly

1. Remove tank with Tool.

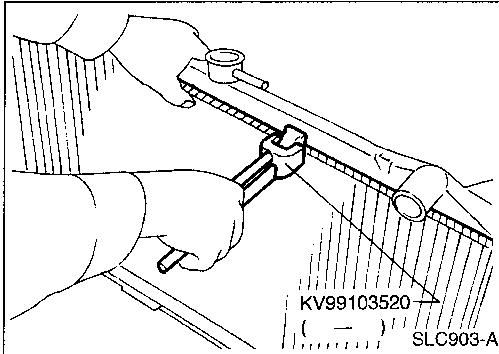

- Grip the crimped edge and bend it upwards so that Tool slips off.

Do not bend excessively.

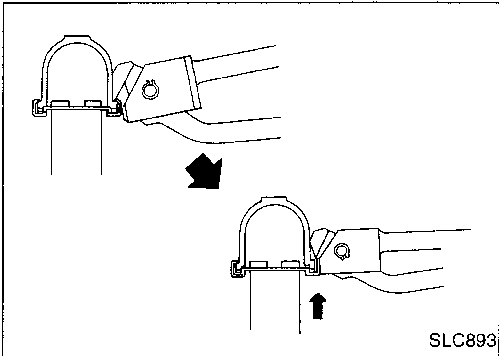

- In areas where Tool cannot be used, use a screwdriver to bend the edge up.

Be careful not to damage tank.

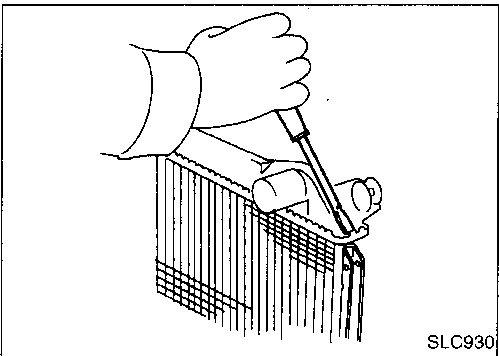

2. Make sure the edge stands straight up.
3. Remove oil cooler from tank. (A/T models only)

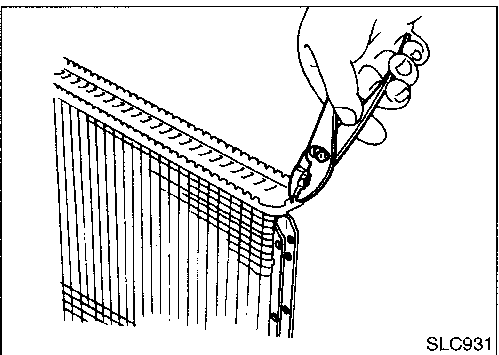

ENGINE COOLING SYSTEM

Radiator (Cont'd)

Assembly

1. Install oil cooler. (A/T models only)
Pay attention to direction of conical washer.

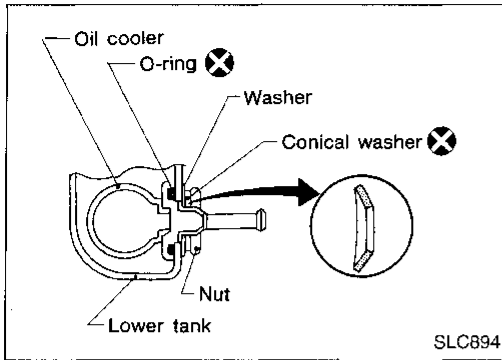

2. Clean contact portion of tank.

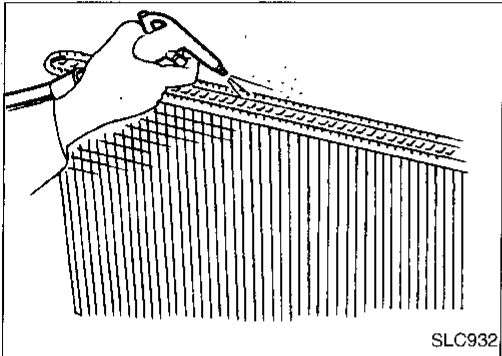

3. Install sealing rubber.
Push it in with fingers.
Be careful not to twist sealing rubber.

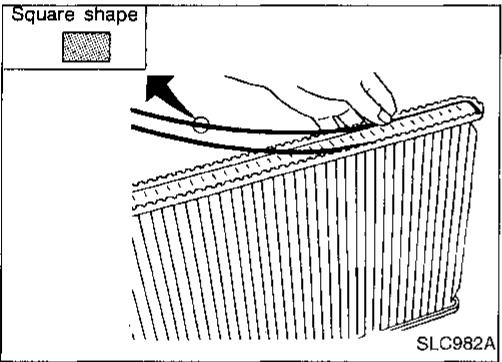

4. Caulk tank in specified sequence with Tool.
Be careful not to excessively caulk the radiator with circular shaped rubber. The Tool is not designed for the standard caulking height (H).

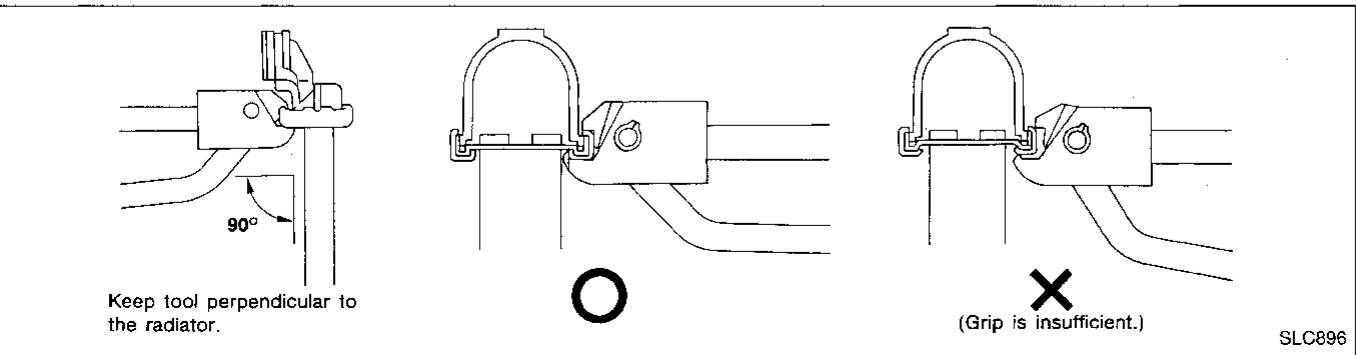
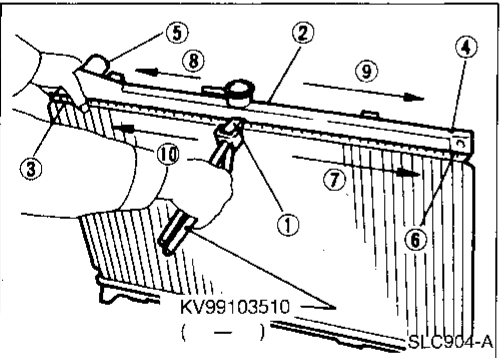

ENGINE COOLING SYSTEM

Radiator (Cont'd)

- Use pliers in the locations where Tool cannot be used.

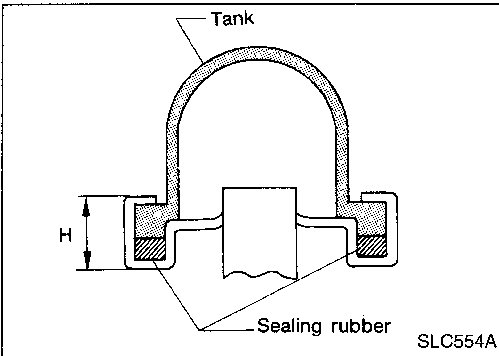
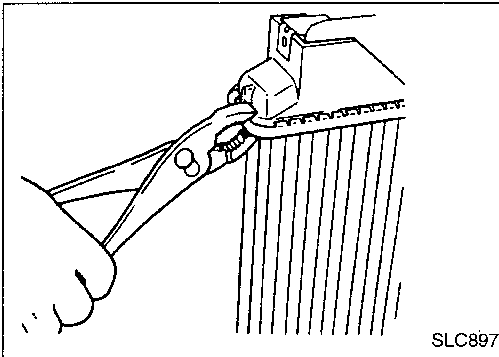

5. Make sure that the rim is completely crimped down.

Standard height "H":

8.0 - 8.4 mm (0.315 - 0.331 in)

6. Confirm that there is no leakage.

Refer to Inspection.

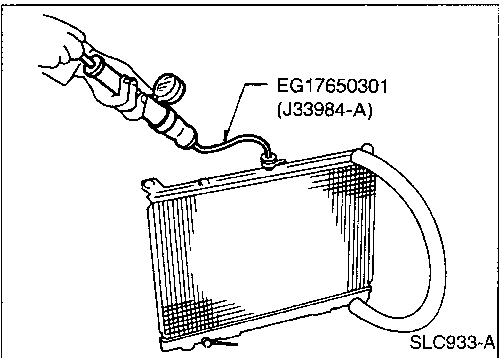

INSPECTION

Apply pressure with Tool.

Specified pressure value:

157 kPa (1.6 kg/cm², 23 psi)

WARNING:

To prevent the risk of the hose coming undone while under pressure, securely fasten it down with a hose clamp. Attach a hose to the oil cooler as well. (A/T models only)

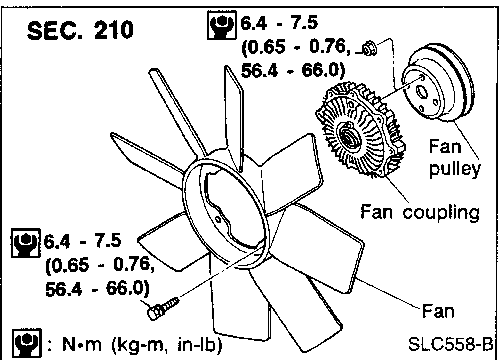

Cooling Fan (Crankshaft driven)

DISASSEMBLY AND ASSEMBLY

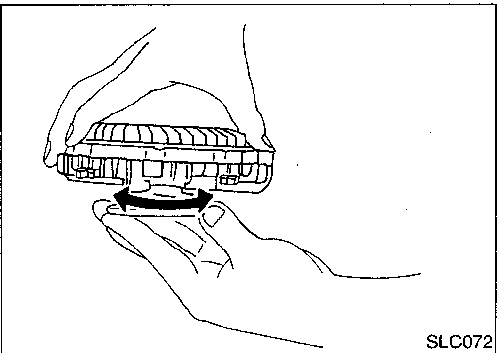

INSPECTION

Check fan coupling for rough operation, oil leakage or bent bimetal.

Cooling Fan Control System

Cooling fan is controlled by ECM (ECCS control module). For details, refer to EC section ("Cooling Fan", "TROUBLE DIAGNOSIS FOR DTC P1900").

GI

MA

EM

LC

EC

FE

CL

MT

AT

PD

FA

RA

BR

ST

RS

BT

HA

EL

IDX

ENGINE COOLING SYSTEM

Overheating Cause Analysis

	Symptom		Check items	
Cooling system parts malfunction	Poor heat transfer	Water pump malfunction	Worn or loose drive belt	—
		Thermostat stuck closed	—	
		Damaged fins	Dust contamination or paper clogging	
			Mechanical damage	
	Clogged radiator cooling tube	Excess foreign material (rust, dirt, sand, etc.)		
	Reduced air flow	Fan coupling does not operate.	—	—
		Cooling fan does not operate.		
		High resistance to fan rotation		
		Damaged fan blades		
	Damaged radiator shroud	—	—	—
	Improper coolant mixture ratio	—	—	—
	Poor coolant quality	—	—	—
	Insufficient coolant	Coolant leaks	Cooling hose	Loose clamp
				Cracked hose
			Water pump	Poor sealing
Radiator cap			Loose	
			Poor sealing	
Radiator			O-ring for damage, deterioration or improper fitting	
		Cracked radiator tank		
Reservoir tank		Cracked radiator core		
Overflowing reservoir tank	Exhaust gas leaks into cooling system	Cylinder head deterioration		
		Cylinder head gasket deterioration		
Except cooling system parts malfunction	—	Abusive driving	High engine rpm under no load	
			Driving in low gear for extended time	
			Driving at extremely high speed	
		Overload on engine	Powertrain system malfunction	—
			Installed improper size wheels and tires	
			Dragging brakes	
	Blocked or restricted air flow	—	Improper ignition timing.	—
			Blocked bumper	
			Blocked radiator grille	
			Blocked radiator	
Blocked condenser	—	—	—	
Installed large fog lamp	—	—	—	

SERVICE DATA AND SPECIFICATIONS (SDS)

Engine Lubrication System

Oil pressure check

Engine speed rpm	Approximate discharge pressure kPa (kg/cm ² , psi)
Idle speed	More than 78 (0.8, 11)
3,000	412 - 481 (4.2 - 4.9, 60 - 70)

Oil pump

		Unit: mm (in)	
Body to outer gear clearance	0.114 - 0.200 (0.0045 - 0.0079)	GI
Inner gear to outer gear tip clearance	0.04 - 0.18 (0.0016 - 0.0071)	MA
Cover to inner gear clearance	0.05 - 0.09 (0.0020 - 0.0035)	EM
Cover to outer gear clearance	0.05 - 0.11 (0.0020 - 0.0043)	EM
Inner gear to brazed portion clearance	0.045 - 0.091 (0.0018 - 0.0036)	LC

Engine Cooling System

Thermostat

Valve opening temperature	°C (°F)	76.5 (170)
Valve lift	mm/°C (in/°F)	More than 10/90 (0.39/194)

Radiator

		Unit: kPa (kg/cm ² , psi)	
Cap relief pressure			FE
Standard		78 - 98 (0.8 - 1.0, 11 - 14)	CL
Limit		59 - 98 (0.6 - 1.0, 9 - 14)	
Leakage test pressure		157 (1.6, 23)	MT

EC

FE

CL

MT

AT

PD

FA

RA

BR

ST

RS

BT

HA

EL

IDX