

SECTION **CL**

GI

MA

EM

LC

EC

FE

CL

MT

AT

PD

FA

RA

BR

ST

RS

BT

HA

EL

IDX

CONTENTS

PRECAUTIONS AND PREPARATION2	Clutch Master Cylinder6
Precautions.....2	Operating Cylinder.....7
Special Service Tools2	CLUTCH RELEASE MECHANISM8
Commercial Service Tools2	CLUTCH DISC AND CLUTCH COVER10
CLUTCH SYSTEM3	Clutch Disc.....10
INSPECTION AND ADJUSTMENT4	Clutch Cover and Flywheel11
Adjusting Clutch Pedal4	SERVICE DATA AND SPECIFICATIONS (SDS)12
Bleeding Procedure5	General Specifications.....12
HYDRAULIC CLUTCH CONTROL6	Inspection and Adjustment12

PRECAUTIONS AND PREPARATION

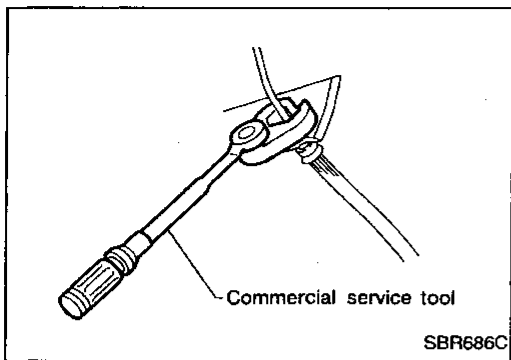

Precautions

- Recommended fluid is brake fluid "DOT 3".
- Never reuse drained brake fluid.
- Be careful not to splash brake fluid on painted areas.
- When removing and installing clutch piping, use Tool.
- Use new brake fluid to clean or wash all parts of master cylinder, operating cylinder and clutch damper.
- Never use mineral oils such as gasoline or kerosene. It will ruin the rubber parts of the hydraulic system.

WARNING:

After cleaning the clutch disc, wipe it with a dust collector. Do not use compressed air.

Special Service Tools

The actual shapes of Kent-Moore tools may differ from those of special service tools illustrated here.

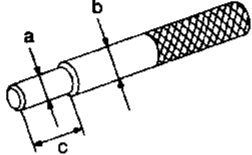
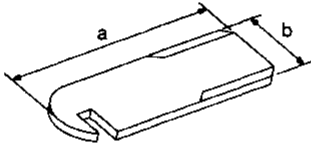
Tool number (Kent-Moore No.) Tool name	Description
ST20630000 (J26366) Clutch aligning bar	 <p style="text-align: right;">Installing clutch cover and clutch disc</p> <p style="text-align: right;">a: 15.9 mm (0.626 in) dia. b: 22.8 mm (0.898 in) dia. c: 55 mm (2.17 in)</p>
ST20050240 (—) Diaphragm spring adjusting wrench	 <p style="text-align: right;">Adjusting unevenness of diaphragm spring of clutch cover</p> <p style="text-align: right;">a: 150 mm (5.91 in) b: 25 mm (0.98 in)</p>

Commercial Service Tools

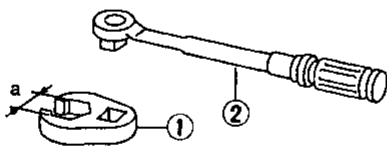
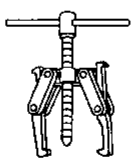
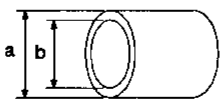
Tool name	Description
① Flare nut crowfoot ② Torque wrench	 <p style="text-align: right;">Removing and installing clutch piping</p> <p style="text-align: right;">a: 10 mm (0.39 in)</p>
Bearing puller	 <p style="text-align: right;">Removing release bearing</p>
Bearing drift	 <p style="text-align: right;">Installing release bearing</p> <p style="text-align: right;">a: 52 mm (2.05 in) dia. b: 45 mm (1.77 in) dia.</p>

Adjusting Clutch Pedal

- Adjust pedal height with pedal stopper or ASCD cancel switch.
Pedal height "H":
 192 - 202 mm (7.56 - 7.95 in)

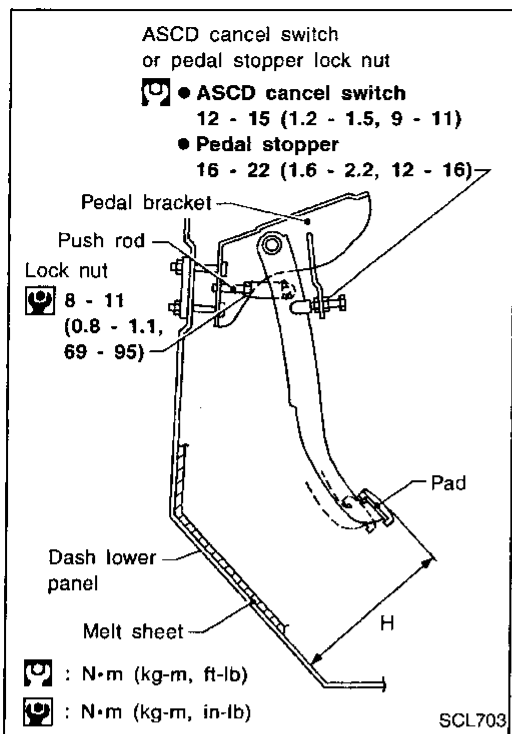

- Adjust pedal free play with master cylinder push rod. Then tighten lock nut.
Pedal free play "A":
 9 - 16 mm (0.35 - 0.63 in)
- Push or step on clutch pedal until resistance is felt, and check the distance the pedal moves.

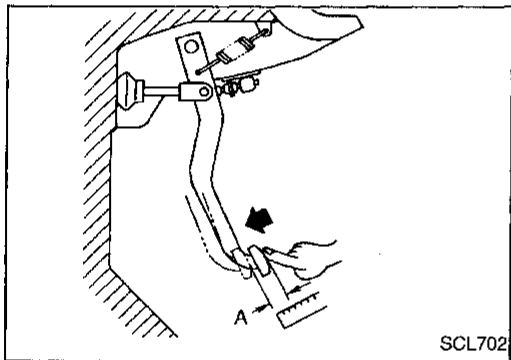

— MODELS WITH CLUTCH INTERLOCK SYSTEM —

- Adjust clearance "C" shown in the figure while fully depressing clutch pedal.
Clearance C:
 0.3 - 1.0 mm (0.012 - 0.039 in)

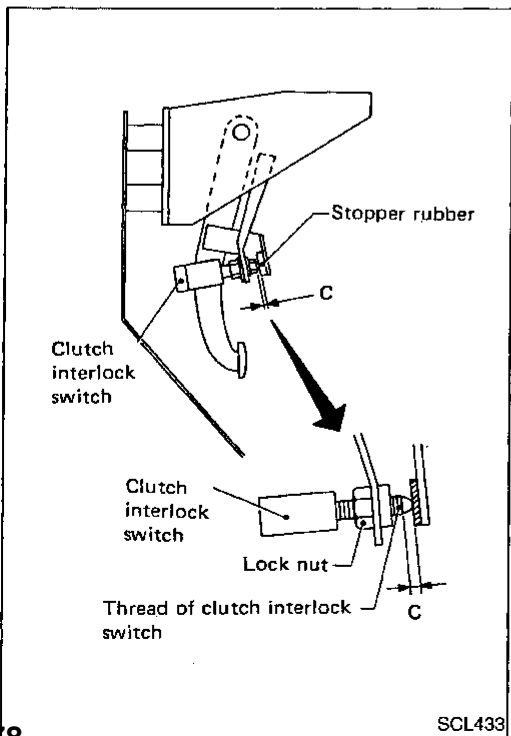

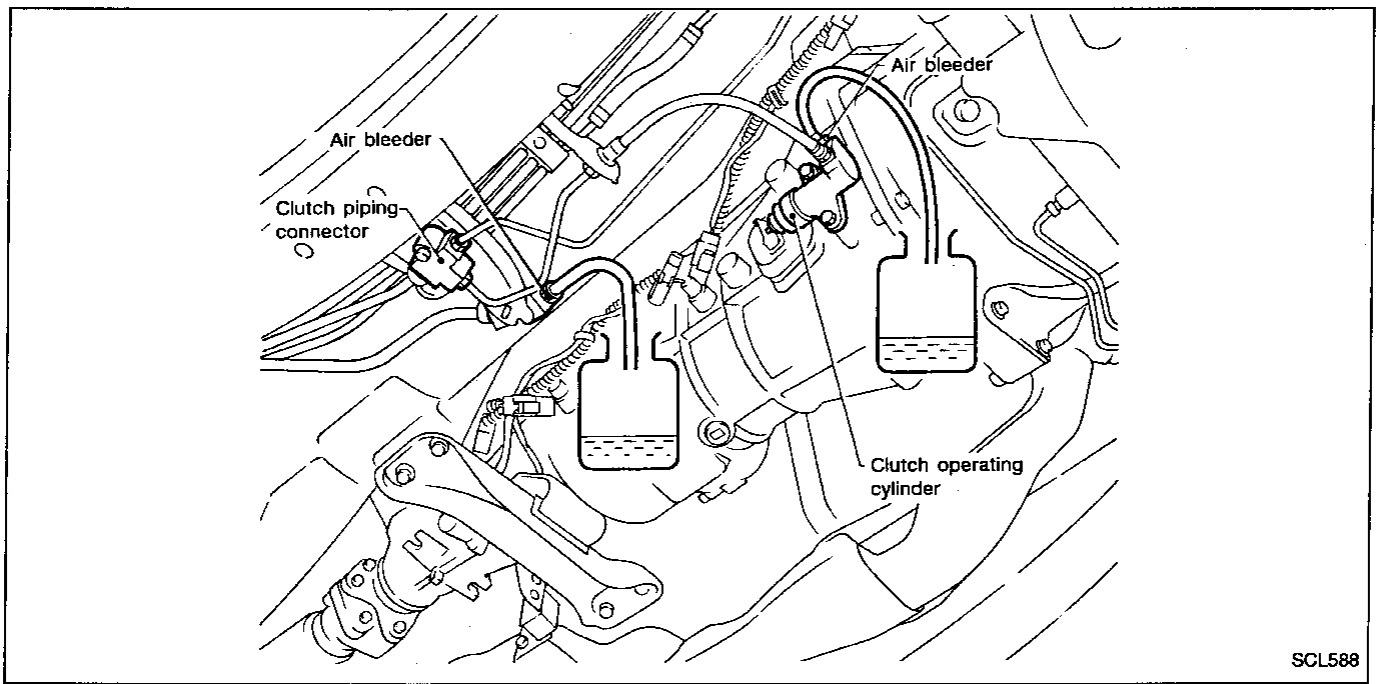

GI
MA
EM
LC
EC
FE

CL

Bleeding Procedure

1. Bleed air from clutch operating cylinder according to the following procedure.

Carefully monitor fluid level at master cylinder during bleeding operation.

- a. Top up reservoir with recommended brake fluid.
 - b. Connect a transparent vinyl tube to air bleeder valve.
 - c. Fully depress clutch pedal several times.
 - d. With clutch pedal depressed, open bleeder valve to release air.
 - e. Close bleeder valve.
 - f. Repeat steps c through e above until brake fluid flows from air bleeder valve without air bubbles.
2. Bleed air from clutch piping connector according to the above same procedure.
3. Repeat the above bleeding procedures 1 and 2 several times.

MT
AT
PD
FA
RA

Remarks

When replacing clutch tube, install new one parallel to body floor panel. If not, air bleeding might be difficult.

BR

ST

RS

BT

HA

EL

IDX

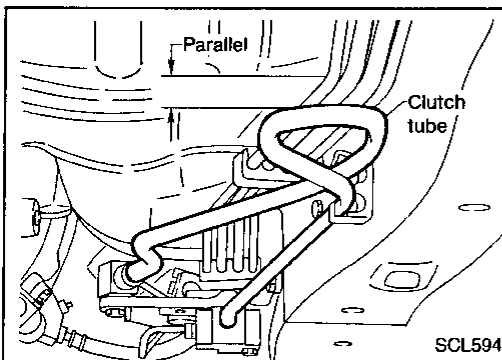

Clutch Master Cylinder

SEC. 305

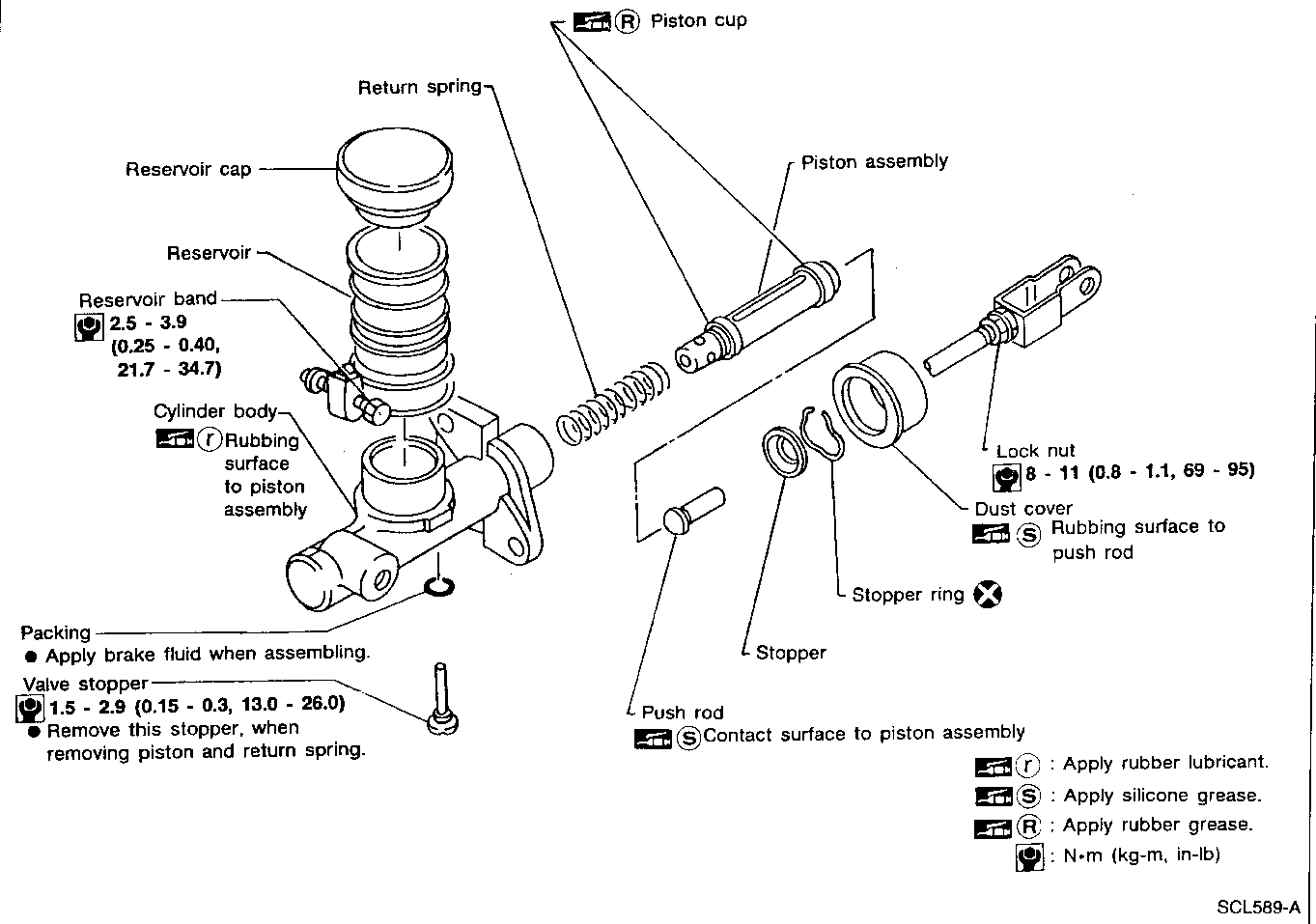

DISASSEMBLY AND ASSEMBLY

- Push piston into cylinder body with screwdriver when removing and installing valve stopper.

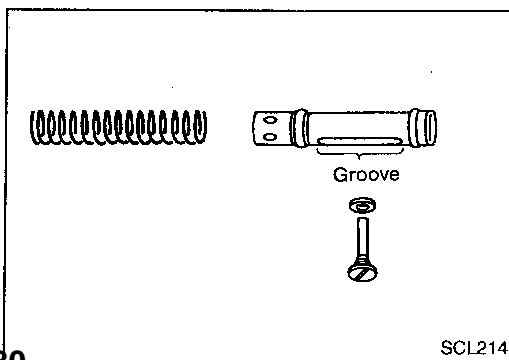

- Align groove of piston assembly and valve stopper when installing valve stopper.
- Check direction of piston cups.

HYDRAULIC CLUTCH CONTROL

Clutch Master Cylinder (Cont'd)

INSPECTION

- Check cylinder and piston rubbing surface for uneven wear, rust or damage. Replace if necessary.
- Check piston with piston cup for wear or damage. Replace if necessary.
- Check return spring for wear or damage. Replace if necessary.
- Check reservoir for deformation or damage. Replace if necessary.
- Check dust cover for cracks, deformation or damage. Replace if necessary.

Operating Cylinder

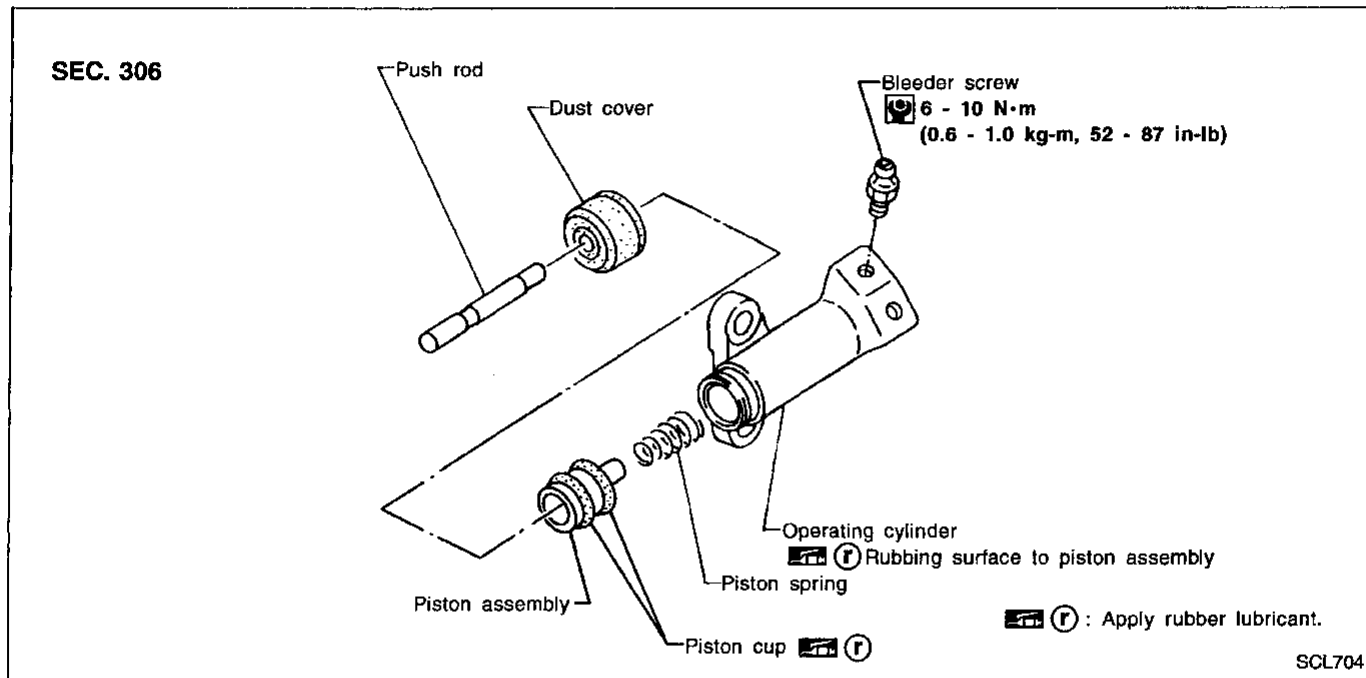

INSPECTION

- Check rubbing surface of cylinder for wear, rust or damage. Replace if necessary.
- Check piston with piston cup for wear or damage. Replace if necessary.
- Check piston spring for wear or damage. Replace if necessary.
- Check dust cover for cracks, deformation or damage. Replace if necessary.

GI
MA
EM
LC
EC
FE
CL
MT
AT
PD
FA
RA
BR
ST
RS
BT
HA
EL
IDX

CLUTCH RELEASE MECHANISM

SEC. 321

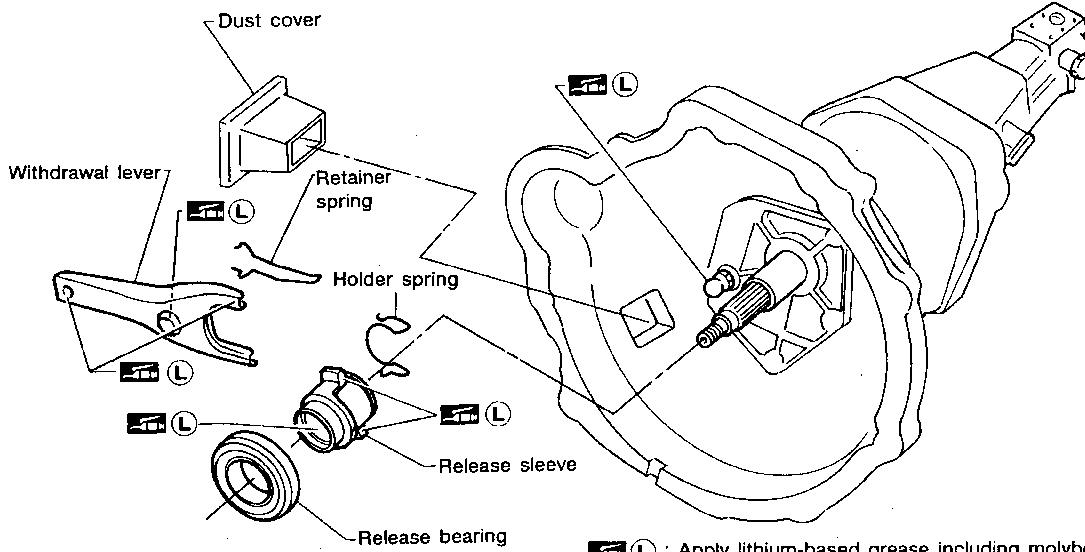

SCL603

REMOVAL AND INSTALLATION

- Install retainer spring and holder spring.

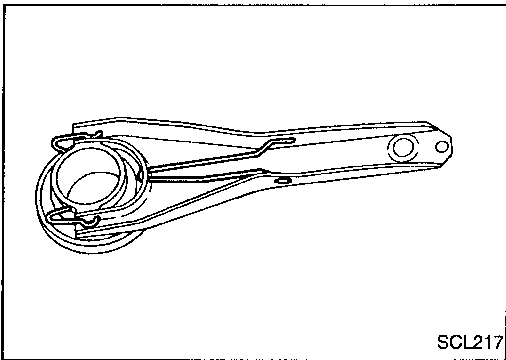

- Remove release bearing.

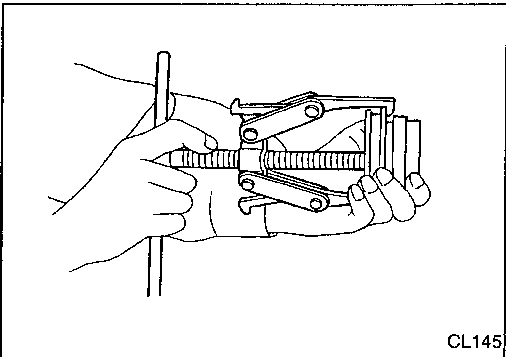

- Install release bearing with suitable drift.

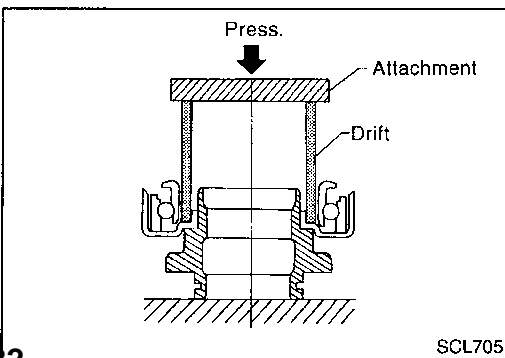

CLUTCH RELEASE MECHANISM

INSPECTION

- Check release bearing to see that it rolls freely and is free from noise, cracks, pitting or wear. Replace if necessary.
- Check release sleeve and withdrawal lever rubbing surface for wear, rust or damage. Replace if necessary.

GI

MA

EM

LC

EC

FE

CL

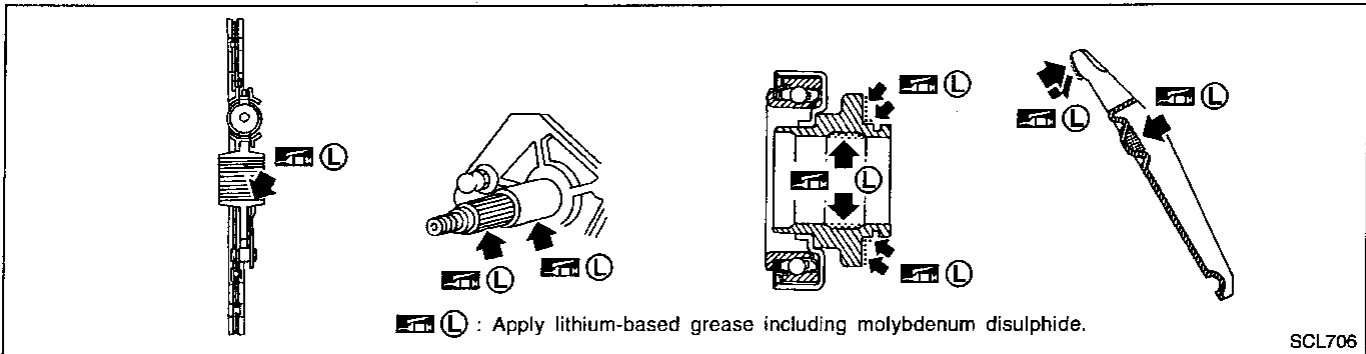

LUBRICATION

- Apply recommended grease to contact surface and rubbing surface.
- Too much lubricant might damage clutch disc facing.

MT

AT

PD

FA

RA

BR

ST

RS

BT

HA

EL

IDX

483

CLUTCH DISC AND CLUTCH COVER

SEC. 300

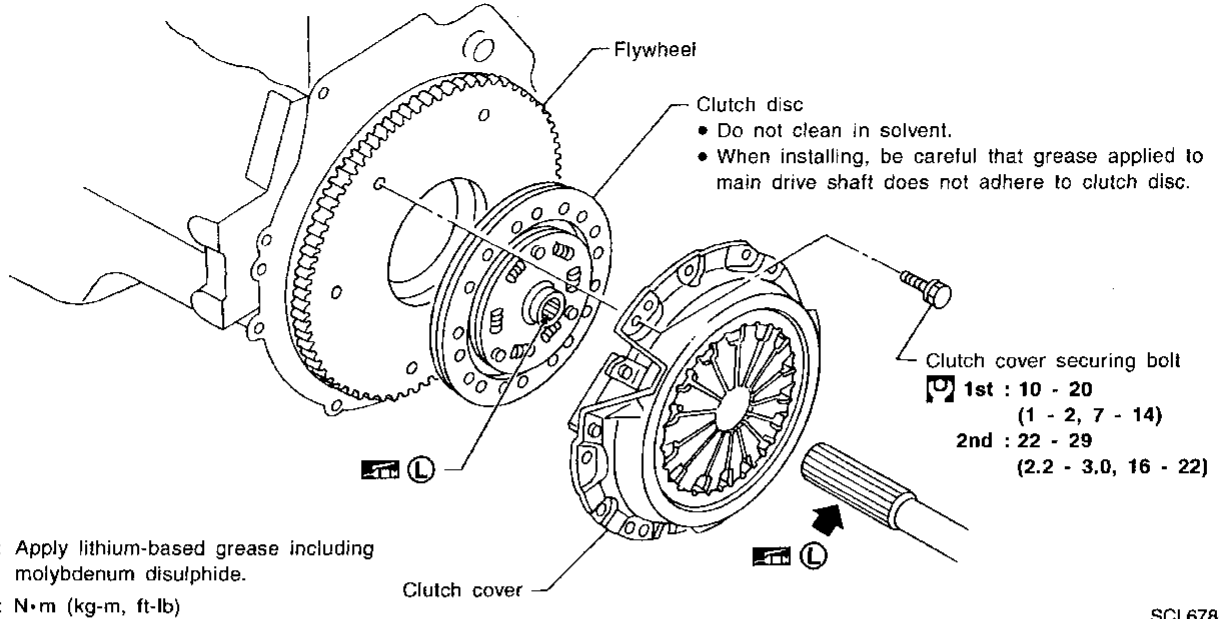

SCL678-A

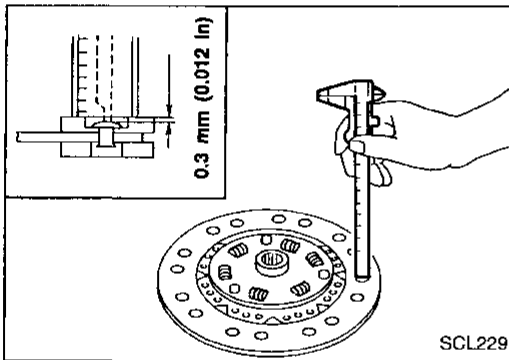

Clutch Disc

INSPECTION

Check the following items, and replace if necessary.

- Clutch disc, for burns, discoloration, oil or grease leakage
- Clutch disc, for wear of facing

Wear limit of facing surface to rivet head:
0.3 mm (0.012 in)

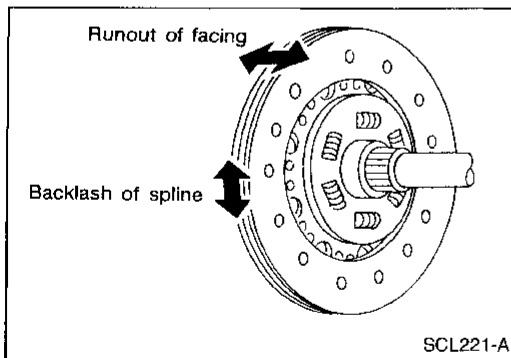

- Clutch disc, for backlash of spline and runout of facing
- Maximum backlash of spline (at outer edge of disc):**
0.9 mm (0.035 in)

Runout limit:
1.0 mm (0.039 in)

Distance of runout check point (from hub center):
107.5 mm (4.23 in)

INSTALLATION

- Apply recommended grease to contact surface of splines.
- Too much lubricant may damage clutch disc facing.

CLUTCH DISC AND CLUTCH COVER

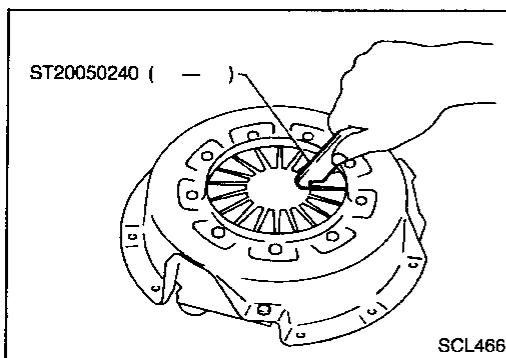

Clutch Cover and Flywheel

INSPECTION AND ADJUSTMENT

- Check clutch cover, installed on vehicle, for uneven diaphragm spring toe height.
Uneven limit:
0.7 mm (0.028 in)
- If out of limit, adjust the height with Tool.

GI

MA

EM

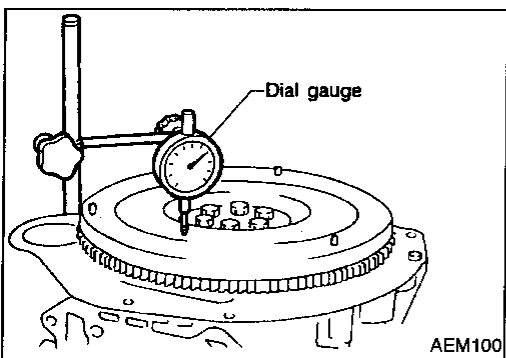

FLYWHEEL INSPECTION

CAUTION:

Do not allow any magnetic materials to contact the ring gear teeth.

- Inspect contact surface of flywheel for slight burns or discoloration. Clean flywheel with emery paper.
- Check flywheel runout.

Maximum allowable runout:

Refer to EM section ("Inspection", "CYLINDER BLOCK").

LC

EC

FE

CL

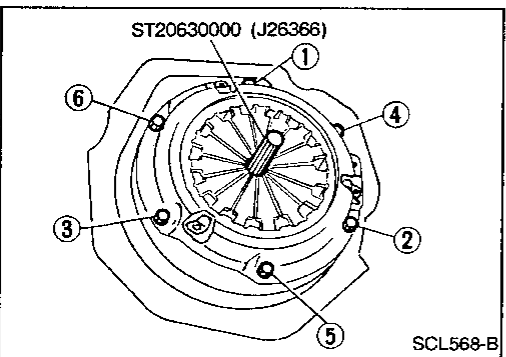

INSTALLATION

- Insert Tool into clutch disc hub when installing clutch cover and disc.
- Be careful not to allow grease to contaminate clutch facing.
- Tighten bolts in numerical order, in two steps.

First step:

: 10 - 20 N-m (1 - 2 kg-m, 7 - 14 ft-lb)

Final step:

: 22 - 29 N-m (2.2 - 3.0 kg-m, 16 - 22 ft-lb)

MT

AT

PD

FA

RA

BR

ST

RS

BT

HA

EL

IDX

485

SERVICE DATA AND SPECIFICATIONS (SDS)

General Specifications

CLUTCH CONTROL SYSTEM

Type of clutch control	Hydraulic
------------------------	-----------

CLUTCH MASTER CYLINDER

Inner diameter	mm (in)	15.87 (5/8)
----------------	---------	-------------

CLUTCH OPERATING CYLINDER

Inner diameter	mm (in)	19.05 (3/4)
----------------	---------	-------------

CLUTCH PEDAL

Unit: mm (in)

Pedal height "H"*1	192 - 202 (7.56 - 7.95)
Pedal free play "A" (At pedal pad)	9 - 16 (0.35 - 0.63)
Clearance "C" (between pedal stopper rubber and clutch interlock switch)*2	0.3 - 1.0 (0.012 - 0.039)

*1: Measured from surface of dash lower panel to pedal pad

*2: Clutch pedal fully depressed

CLUTCH DISC

Unit: mm (in)

Model	225
Wear limit of facing surface to rivet head	0.3 (0.012)
Runout limit of facing	1.0 (0.039)
Distance of runout check point (from the hub center)	107.5 (4.23)
Maximum backlash of spline (at outer edge of disc)	0.9 (0.035)

CLUTCH DISC

Unit: mm (in)

Model	225
Facing size (Outer dia. x inner dia. x thickness)	225 x 150 x 3.5 (8.86 x 5.91 x 0.138)
Thickness of disc assembly With load	7.6 - 8.0 (0.299 - 0.315) with 5,394 N (550 kg, 1,213 lb)

CLUTCH COVER

Model	225
Set load	N (kg, lb) 5,394 (550, 1,213)

Inspection and Adjustment

CLUTCH COVER

Unit: mm (in)

Model	225
Uneven limit of diaphragm spring toe height	0.7 (0.028)