

SECTION MA

GI

MA

EM

LC

EC

FE

CL

MT

AT

PD

FA

RA

BR

ST

RS

BT

HA

EL

IDX

CONTENTS

PRECAUTIONS AND PREPARATION	2	CHASSIS AND BODY MAINTENANCE	17
Supplemental Restraint System (SRS) "AIR BAG".....	2	Checking Exhaust System.....	17
Special Service Tool	2	Checking Clutch Fluid Level and Leaks.....	17
GENERAL MAINTENANCE	3	Checking M/T Oil.....	17
PERIODIC MAINTENANCE	5	Changing M/T Oil.....	17
Schedule 1	6	Checking A/T Fluid	18
Schedule 2.....	7	Changing A/T Fluid	18
RECOMMENDED FLUIDS AND LUBRICANTS	8	Checking Differential Gear Oil.....	19
Fluids and Lubricants	8	Changing Differential Gear Oil	19
SAE Viscosity Number	8	Balancing Wheels	19
Anti-freeze Coolant Mixture Ratio	9	Tire Rotation	19
ENGINE MAINTENANCE	10	Checking Brake Fluid Level and Leaks.....	19
Checking Drive Belts	10	Checking Brake Lines and Cables.....	20
Changing Engine Coolant.....	11	Checking Disc Brake	20
Checking Fuel Lines	12	Checking Steering Gear and Linkage	20
Changing Fuel Filter	13	Checking Power Steering Fluid and Lines	21
Changing Air Cleaner Filter	13	Lubricating Locks, Hinges and Hood Latches.....	22
Changing Engine Oil.....	14	Checking Seat Belts, Buckles, Retractors, Anchors and Adjusters.....	22
Changing Oil Filter.....	14	SERVICE DATA AND SPECIFICATIONS (SDS)	23
Changing Spark Plugs.....	15	Engine Maintenance	23
Checking EVAP Vapor Lines	16	Chassis and Body Maintenance.....	23

PRECAUTIONS AND PREPARATION

Supplemental Restraint System (SRS) "AIR BAG"

The Supplemental Restraint System "AIR BAG", used along with a seat belt, helps to reduce the risk or severity of injury to the driver and front passenger in a frontal collision. The Supplemental Restraint System consists of air bag modules (located in the center of the steering wheel and on the instrument panel on the passenger side), a diagnosis sensor unit, warning lamp, wiring harness and spiral cable. Information necessary to service the system safely is included in the **RS section** of this Service Manual.

WARNING:

- To avoid rendering the SRS inoperative, which could increase the risk of personal injury or death in the event of a collision which would result in air bag inflation, all maintenance must be performed by an authorized NISSAN dealer.
- Improper maintenance, including incorrect removal and installation of the SRS, can lead to personal injury caused by unintentional activation of the system.
- Do not use electrical test equipment on any circuit related to the SRS unless instructed to in this Service Manual. SRS wiring harnesses are covered with yellow insulation either just before the harness connectors or for the complete harness, for easy identification.

Special Service Tool

The actual shapes of Kent-Moore tools may differ from those of special service tools illustrated here.

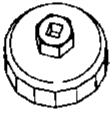
Tool number (Kent-Moore No.) Tool name	Description
KV10105901 (J34274) Oil filter cap wrench	<div style="text-align: right; margin-bottom: 10px;">Removing oil filter</div> <div style="text-align: center;">  <p style="margin-left: 20px;">15 faces, inner span: 80 mm (3.15 in) (Face to opposite corner)</p> </div> <p style="margin-top: 10px;">NT689</p>

GENERAL MAINTENANCE

General maintenance includes those items which should be checked during normal day-to-day operation of the vehicle. They are essential if the vehicle is to continue operating properly. The owners can perform checks and inspections themselves or have their NISSAN dealers do them.

Item	Reference page	
OUTSIDE THE VEHICLE		
The maintenance items listed here should be performed from time to time, unless otherwise specified.		
Tires Check the pressure with a gauge periodically when at a service station, including the spare, and adjust to the specified pressure if necessary. Check carefully for damage, cuts or excessive wear.	—	GI MA EM
Wheel nuts When checking the tires, make sure no nuts are missing, and check for any loose nuts. Tighten if necessary.	—	LC
Tire rotation Tires should be rotated every 12,000 km (7,500 miles).	MA-19	LC
Wheel alignment and balance If the vehicle pulls to either side while driving on a straight and level road, or if you detect uneven or abnormal tire wear, there may be a need for wheel alignment. If the steering wheel or seat vibrates at normal highway speeds, wheel balancing may be needed.	MA-19 FA-7	EC
Windshield wiper blades Check for cracks or wear if they do not wipe properly.	—	FE
Doors and engine hood Check that all doors and the engine hood operate smoothly as well as the trunk lid and back hatch. Also make sure, that all latches lock securely. Lubricate if necessary. Make sure that the secondary latch keeps the hood from opening when the primary latch is released. When driving in areas using road salt or other corrosive materials, check lubrication frequently.	MA-22	CL MT
INSIDE THE VEHICLE		
The maintenance items listed here should be checked on a regular basis, such as when performing periodic maintenance, cleaning the vehicle, etc.		
Lamps Make sure that the headlamps, stop lamps, tail lamps, turn signal lamps, and other lamps are all operating properly and installed securely. Also check headlamp aim.	—	AT PD
Warning lamps and buzzers/chimes Make sure that all warning lamps and buzzers/chimes are operating properly.	—	FA
Windshield wiper and washer Check that the wipers and washer operate properly and that the wipers do not streak.	—	RA
Windshield defroster Check that air comes out of the defroster outlets properly and in good quantity when operating the heater or air conditioner.	—	RA
Steering wheel Check that it has the specified play. Be sure to check for changes in the steering condition, such as excessive play, hard steering or strange noises. Free play: Less than 35 mm (1.38 in)	—	BR
Seats Check seat position controls such as seat adjusters, seatback recliner, etc. to make sure they operate smoothly and that all latches lock securely in every position. Check that the head restraints move up and down smoothly and that the locks (if equipped) hold securely in all latched positions. Check that the latches lock securely for folding-down rear seatbacks.	—	ST RS
Seat belts Check that all parts of the seat belt system (e.g. buckles, anchors, adjusters and retractors) operate properly and smoothly and are installed securely. Check the belt webbing for cuts, fraying, wear or damage.	MA-22 RS-5	BT

HA

EL

IDX

GENERAL MAINTENANCE

Item	Reference page
Clutch pedal Make sure the pedal operates smoothly and check that it has the proper free play.	CL-4
Brakes Check that the brake does not pull the vehicle to one side when applied.	—
Brake pedal and booster Check the pedal for smooth operation and make sure it has the proper distance under it when depressed fully. Check the brake booster function. Be sure to keep floor mats away from the pedal.	BR-8, 12
Parking brake Check that the lever has the proper travel and make sure that the vehicle is held securely on a fairly steep hill when only the parking brake is applied.	BR-25
Automatic transmission "Park" mechanism Check that the brake pedal must be depressed for the selector lever to be moved from the "P" position. On a fairly steep hill check that the vehicle is held securely with the selector lever in the "P" position without applying any brakes.	—
UNDER THE HOOD AND VEHICLE	
The maintenance items listed here should be checked periodically (e.g. each time you check the engine oil or refuel).	
Windshield washer fluid Check that there is adequate fluid in the tank.	—
Engine coolant level Check the coolant level when the engine is cold.	MA-11
Radiator and hoses Check the front of the radiator and clean off any dirt, insects, leaves, etc., that may have accumulated. Make sure the hoses have no cracks, deformation, deterioration or loose connections.	—
Brake and clutch fluid levels Make sure that the brake and clutch fluid levels are between the "MAX" and "MIN" lines on the reservoir.	MA-17, 19
Battery Check the fluid level in each cell. It should be between the "MAX" and "MIN" lines.	—
Engine drive belts Make sure that no belt is frayed, worn, cracked or oily.	MA-10
Engine oil level Check the level on the dipstick after parking the vehicle on a level spot and turning off the engine.	MA-14
Power steering fluid level and lines Check the level on the dipstick with the engine off. Check the lines for improper attachment, leaks, cracks, etc.	MA-21
Automatic transmission fluid level Check the level on the dipstick after putting the selector lever in "P" with the engine idling.	MA-18
Exhaust system Make sure there are no loose supports, cracks or holes. If the sound of the exhaust seems unusual or there is a smell of exhaust fumes, immediately locate the trouble and correct it.	MA-17
Underbody The underbody is frequently exposed to corrosive substances such as those used on icy roads or to control dust. It is very important to remove these substances, otherwise rust will form on the floor pan, frame, fuel lines and around the exhaust system. At the end of winter, the underbody should be thoroughly flushed with plain water, being careful to clean those areas where mud and dirt can easily accumulate.	—
Fluid leaks Check under the vehicle for fuel, oil, water or other fluid leaks after the vehicle has been parked for a while. Water dripping from the air conditioner after use is normal. If you should notice any leaks or if gasoline fumes are evident, check for the cause and correct it immediately.	—

PERIODIC MAINTENANCE

Two different maintenance schedules are provided, and should be used, depending upon the conditions in which the vehicle is mainly operated. **After 60,000 miles (96,000 km) or 48 months, continue the periodic maintenance at the same mileage/time intervals.**

SCHEDULE 1

Follow Periodic Maintenance Schedule 1 if your driving habits frequently includes one or more of the following driving conditions:

- Repeated short trips of less than 5 miles (8 km).
- Repeated short trips of less than 10 miles (16 km) with outside temperatures remaining below freezing.
- Operating in hot weather in stop-and-go "rush hour" traffic.
- Extensive idling and/or low speed driving for long distances, such as police, taxi or door-to-door delivery use.
- Driving in dusty conditions.
- Driving on rough, muddy, or salt spread roads.
- Towing a trailer, using a camper or a car-top carrier.

SCHEDULE 2

Follow Periodic Maintenance Schedule 2 if none of the driving conditions shown in Schedule 1 apply to your driving habits.

GI

MA

EM

LC

EC

FE

CL

MT

AT

PD

FA

RA

BR

ST

RS

BT

HA

EL

IDX

PERIODIC MAINTENANCE

Schedule 1

Abbreviations: R = Replace I = Inspect. Correct or replace if necessary. []: At the mileage intervals only

MAINTENANCE OPERATION	MAINTENANCE INTERVAL												Reference page					
	Miles x 1,000	3.75	7.5	11.25	15	18.75	22.5	26.25	30	33.75	37.5	41.25		45	48.75	52.5	56.25	60
Perform at number of miles, kilometers or months, whichever comes first.		(6)	(12)	(18)	(24)	(30)	(36)	(42)	(48)	(54)	(60)	(66)	(72)	(78)	(84)	(90)	(96)	
Months	3	6	9	12	15	18	21	24	27	30	33	36	39	42	45	48		
Emission control system maintenance																		
Drive belts	See NOTE (1)																I*	MA-10
Air cleaner filter	See NOTE (2)							[R]									[R]	MA-13
EVAP vapor lines								I*									I*	MA-16
Fuel lines								I*									I*	MA-12
Fuel filter*	See NOTE (3)																	MA-13
Engine coolant	See NOTE (4)																	M/A-11
Engine oil		R	R	R	R	R	R	R	R	R	R	R	R	R	R	R	R	MA-14
Engine oil filter		R	R	R	R	R	R	R	R	R	R	R	R	R	R	R	R	MA-14
Spark plugs (Use PLATINUM-TIPPED type)																	[R]	MA-15
Intake & exhaust valve clearances*	See NOTE (5)																	EM-30
Chassis and body maintenance																		
Brake lines & cables																		MA-20
Brake pads & discs																		MA-20
Manual and automatic transmission oil and fluid, & differential gear oil	See NOTE (6)																	MA-17, 18, 19
Steering gear & linkage, axle & suspension parts																		MA-20, FA-6, RA-6
Exhaust system																		MA-17
Air bag system	See NOTE (7)																	RS-10

NOTE: (1) After 60,000 miles (96,000 km) or 48 months, inspect every 15,000 miles (24,000 km) or 12 months.
 (2) If operating mainly in dusty conditions, more frequent maintenance may be required.
 (3) If vehicle is operated under extremely adverse weather conditions or in areas where ambient temperatures are either extremely low or extremely high, the filters might become clogged. In such an event, replace them immediately.
 (4) After 60,000 miles (96,000 km) or 48 months, replace every 30,000 miles (48,000 km) or 24 months.
 (5) If valve noise increases, inspect valve clearances.
 (6) If towing a trailer, using a camper or a car-top carrier, or driving on rough or muddy roads, change (not just inspect) oil at every 30,000 miles (48,000 km) or 24 months.
 (7) Inspect the air bag system 10 years after the date of manufacture noted on the FMVSS certification label.
 ★ Maintenance items and intervals with "*" are recommended by NISSAN for reliable vehicle operation. The owner need not perform such maintenance in order to maintain the emission warranty or manufacturer recall liability. Other maintenance items and intervals are required.

PERIODIC MAINTENANCE

Schedule 2

Abbreviations: R = Replace I = Inspect. Correct or replace if necessary. []: At the mileage intervals only

MAINTENANCE OPERATION	MAINTENANCE INTERVAL										Reference page
	Miles x 1,000	7.5	15	22.5	30	37.5	45	52.5	60		
Perform at number of miles, kilometers or months, whichever comes first.	(km x 1,000)	(12)	(24)	(36)	(48)	(60)	(72)	(84)	(96)		
	Months	6	12	18	24	30	36	42	48		
Emission control system maintenance											
Drive bells	See NOTE (1)								I*	MA-10	
Air cleaner filter					[R]				[R]	MA-13	
EVAP vapor lines					I*				I*	MA-16	
Fuel lines					I*				I*	MA-12	
Fuel filter*	See NOTE (2)									MA-13	
Engine coolant	See NOTE (3)								R*	MA-11	
Engine oil		R	R	R	R	R	R	R	R	MA-14	
Engine oil filter		R	R	R	R	R	R	R	R	MA-14	
Spark plugs (Use PLATINUM-TIPPED type)									[R]	MA-15	
Intake & exhaust valve clearances*	See NOTE (4)									EM-30	
Chassis and body maintenance											
Brake lines & cables									I	MA-20	
Brake pads & discs									I	MA-20	
Manual and automatic transmission oil and fluid, & differential gear oil									I	MA-17, 18, 19	
Steering gear linkage, axle & suspension parts									I	MA-20, FA-6, RA-6	
Exhaust system									I	MA-17	
Air bag system	See NOTE (5)									RS-10	

NOTE: (1) After 60,000 miles (96,000 km) or 48 months, inspect every 15,000 miles (24,000 km) or 12 months.
(2) If vehicle is operated under extremely adverse weather conditions or in areas where ambient temperatures are either extremely low or extremely high, the filters might become clogged. In such an event, replace them immediately.
(3) After 60,000 miles (96,000 km) or 48 months, replace every 30,000 miles (48,000 km) or 24 months.
(4) If valve noise increases, inspect valve clearances.
(5) Inspect the air bag system 10 years after the date of manufacture noted on the FMVSS certification label.
 * Maintenance items and intervals with "*" are recommended by NISSAN for reliable vehicle operation. The owner need not perform such maintenance in order to maintain the emission warranty or manufacturer recall liability. Other maintenance items and intervals are required.

CI
MA
 EM
 LG
 LC
 FE
 CL
 MT
 AT
 PD
 FA
 RA
 BR
 ST
 RS
 BT
 HA
 EL
 IDX

RECOMMENDED FLUIDS AND LUBRICANTS

Fluids and Lubricants

	Capacity (Approximate)			Recommended fluids and lubricants
	US measure	Imp measure	Liter	
Engine oil (Refill)				
With oil filter	4 qt	3-3/8 qt	3.8	<ul style="list-style-type: none"> • API SG or SH and Energy Conserving II*2 • API Certification Mark*2
Without oil filter	3-3/4 qt	3-1/8 qt	3.5	
Cooling system (with reservoir tank)	7 qt	5-7/8 qt	6.6	Anti-freeze coolant (Ethylene glycol base)
Manual transmission oil	5-1/4 pt	4-3/8 pt	2.5	API GL-4, Viscosity SAE 75W-90 only
Differential gear oil	2-3/4 pt	2-1/4 pt	1.3	API GL-5*2
Automatic transmission fluid	8-3/4 qt	7-1/4 qt	8.3	Nissan Matic "D" (Continental U.S. and Alaska) or Genuine Nissan Automatic Transmission Fluid (Canada).*3
Power steering fluid	—	—	—	Type DEXRON™III or equivalent
Brake & clutch fluid	—	—	—	Genuine Nissan Brake Fluid*1 or equivalent DOT 3 (US FMVSS No. 116)
Multi-purpose grease	—	—	—	NLGI No. 2 (Lithium soap base)

*1: Contact a Nissan dealer for suitable fluids.

*2: For further details, see "SAE Viscosity Number".

*3: Dexron™ III/Mercon™ or equivalent may also be used. Outside the continental United States and Alaska contact a NISSAN dealership for more information regarding suitable fluids, including recommended brand(s) of Dexron™ III/Mercon™ Automatic Transmission Fluid.

SAE Viscosity Number

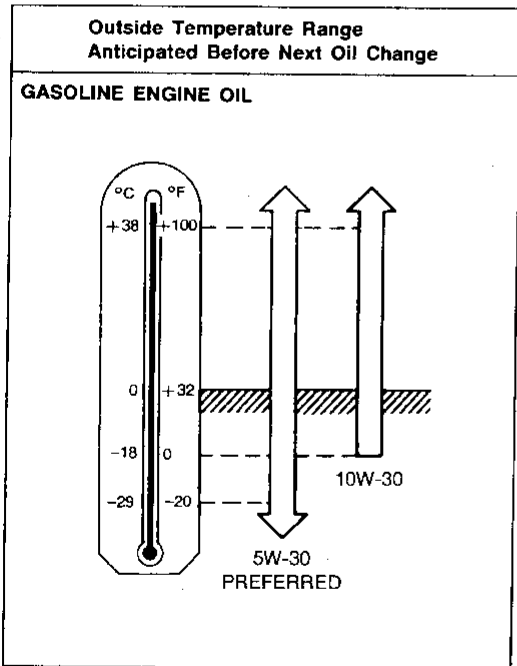

SAE 5W-30 viscosity oil is preferred for all ambient temperatures. SAE 10W-30 viscosity oil may be used if the ambient temperature is above -18°C (0°F).

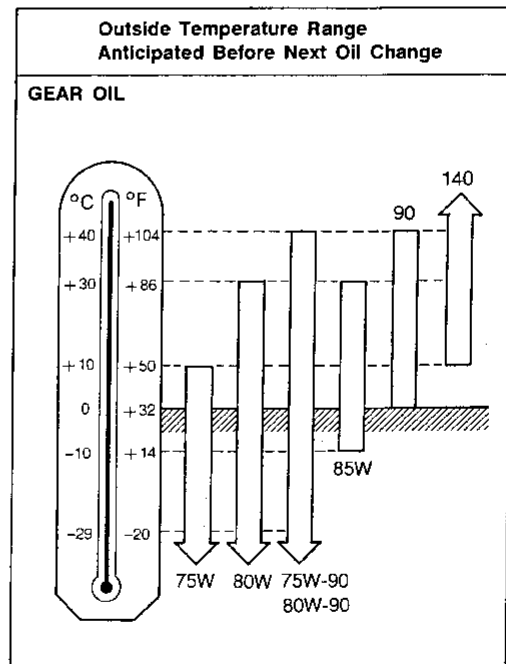

80W-90 for the differential is preferable if the ambient temperature is below 40°C (104°F).

RECOMMENDED FLUIDS AND LUBRICANTS

Anti-freeze Coolant Mixture Ratio

The engine cooling system is filled at the factory with a high-quality, year-round, anti-freeze coolant solution. The anti-freeze solution contains rust and corrosion inhibitors. Therefore, additional cooling system additives are not necessary.

CAUTION:

When adding or replacing coolant, be sure to use only an ethylene glycol anti-freeze with the proper mixture ratio of 50% anti-freeze 50% soft water.

Outside temperature down to		Anti- freeze	Soft water
°C	°F		
-35	-30	50%	50%

Other types of coolant solutions may damage the cooling system.

GI

MA

EM

LC

EC

FE

CL

MT

AT

PD

FA

RA

BR

ST

RS

BT

HA

EL

IDX

ENGINE MAINTENANCE

Checking Drive Belts

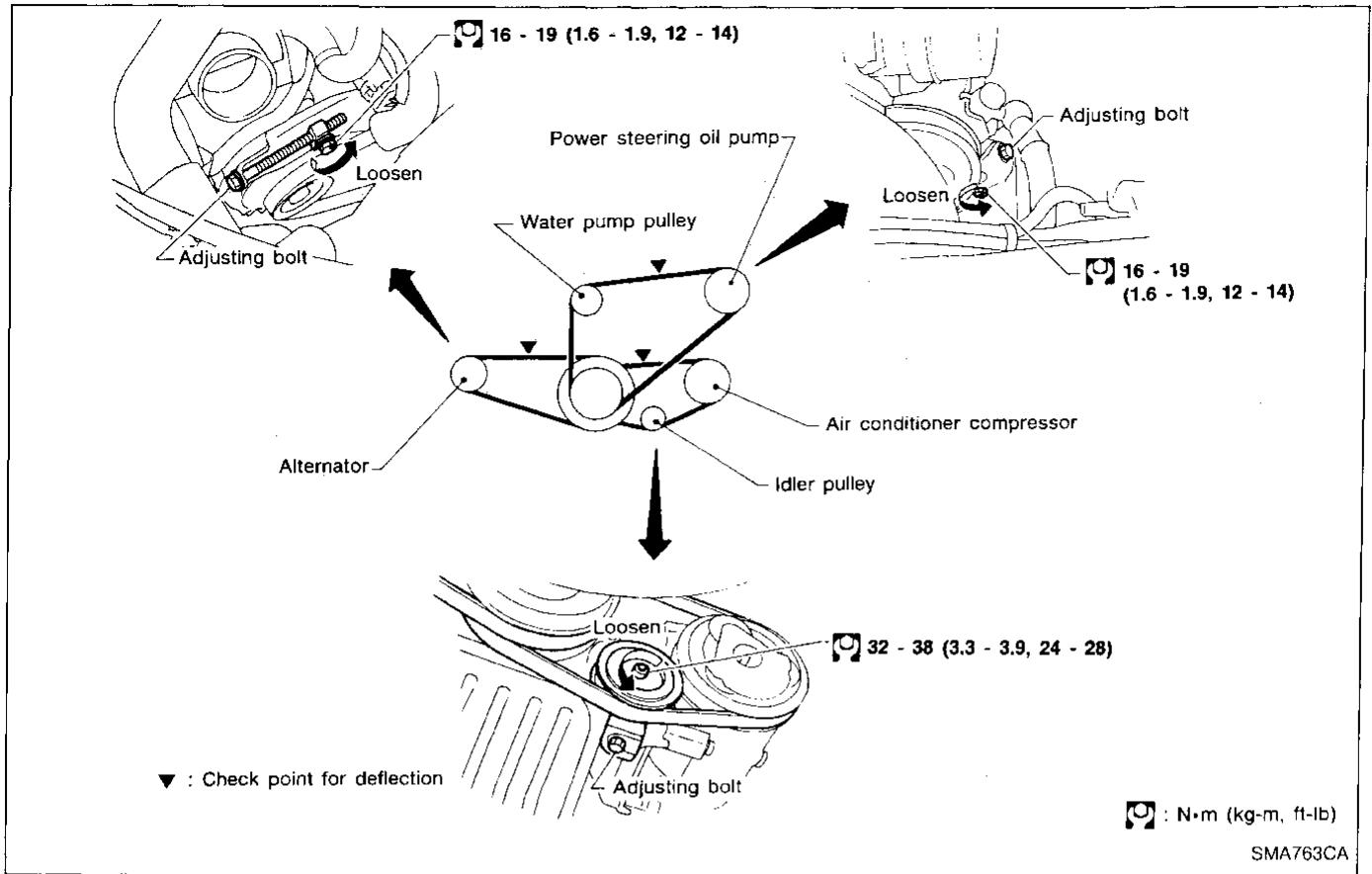

1. Inspect for cracks, fraying, wear or oil adhesion. If necessary, replace with a new one.
2. Inspect drive belt deflections by pushing on the belt midway between pulleys.

Inspect drive belt deflections when engine is cold.

Adjust if belt deflections exceed the limit.

Belt deflection:

Unit: mm (in)

	Used belt deflection		Deflection of new belt
	Limit	Deflection after adjustment	
Alternator	11 (0.43)	7 - 8 (0.28 - 0.31)	6 - 7 (0.24 - 0.28)
Air conditioner compressor	12 (0.47)	7.5 - 8.5 (0.295 - 0.335)	6.5 - 7.5 (0.256 - 0.295)
Power steering oil pump	13 (0.51)	7.5 - 8.5 (0.295 - 0.335)	6.5 - 7.5 (0.256 - 0.295)
Applied pushing force	98 N (10 kg, 22 lb)		

Changing Engine Coolant

WARNING:

To avoid the danger of being scalded, never change the coolant when the engine is hot.

1. Remove undercover.
2. Turn ignition switch "ON" and move heater "TEMP" control lever to "HOT" position. After air mix door moves to "HOT" position, turn ignition switch "OFF".

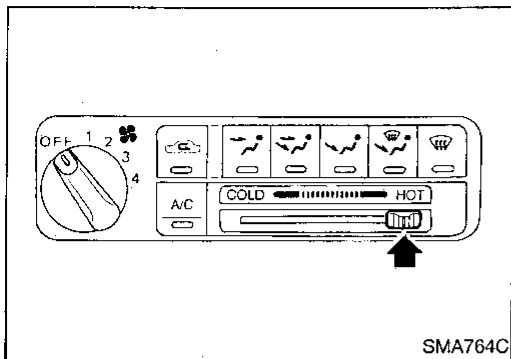

3. Open drain plug at the bottom of radiator, and remove radiator cap.

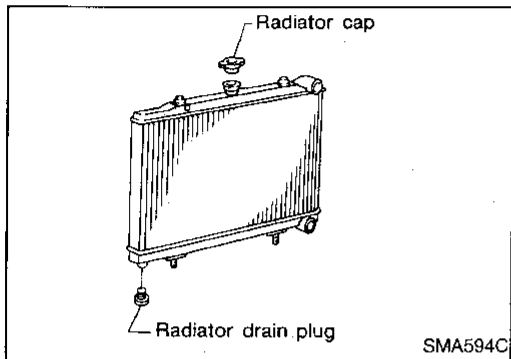

4. Remove air relief plug at water outlet.

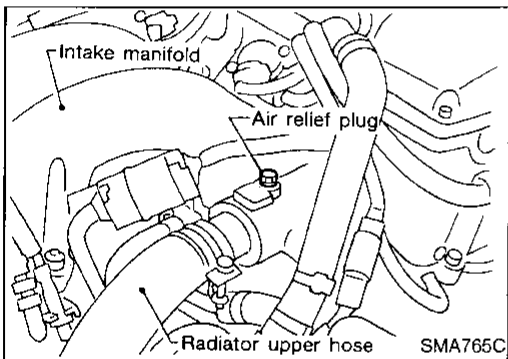

5. Remove drain plug on cylinder block.
6. Close and securely tighten drain plug.

Apply sealant to the thread of drain plug.

: 34 - 44 N·m
(3.5 - 4.5 kg·m, 25 - 33 ft·lb)

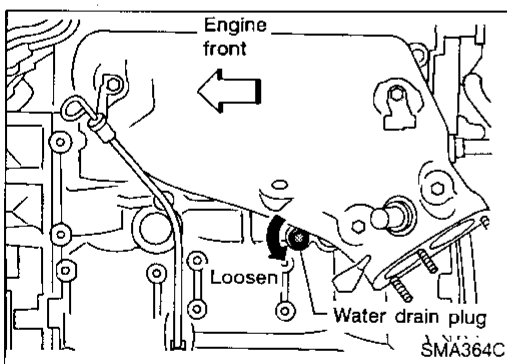

7. Disconnect heater hose (between heater cock and heater core) at heater cock. Before disconnection, remove bolt fixing brake booster hose bracket to intake manifold for easy working.

When refilling after engine removal, never refill the coolant without this procedure. Otherwise, remaining air will cause engine to overheat.

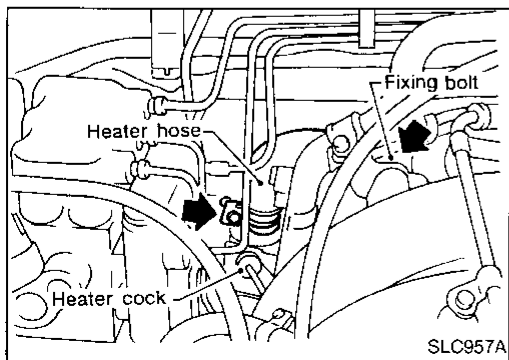

GI

MA

EM

LC

EC

FE

CL

MT

AT

PD

FA

RA

BR

ST

RS

BT

HA

EL

IDX

ENGINE MAINTENANCE

Changing Engine Coolant (Cont'd)

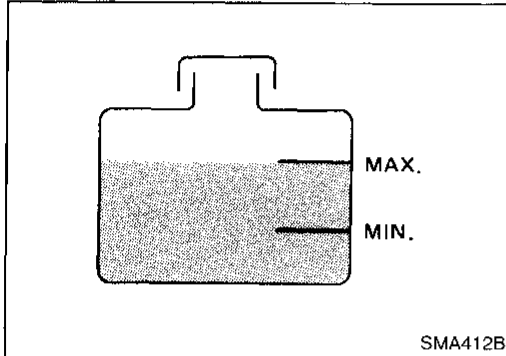
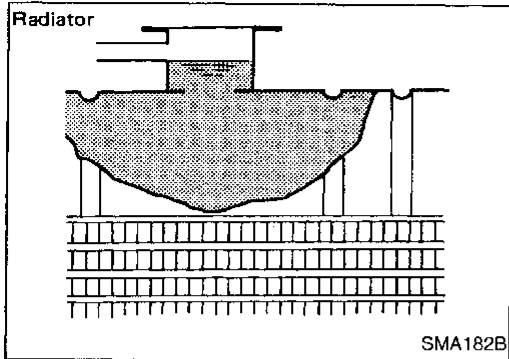

8. Fill radiator with water up to specified level with a filling speed of 2 liters per minute like pouring water by kettle. When water spills from opening at air relief plug or heater cock, close air relief plug or connect heater hose to heater cock.
9. Close radiator cap and run engine.
10. Wait until coolant temperature gauge indicates more than middle level.
11. Be sure thermostat has opened by touching radiator lower hose. If the hose becomes hot, thermostat has opened.
12. Race engine up to 2,500 rpm and keep it for 10 seconds under no-load. Repeat this 2 or 3 times.

Watch coolant temperature gauge so as not to overheat the engine.

13. Stop engine and wait until it cools down.
 - Cool down using a fan to reduce the time.
14. Repeat steps 3 through 13 until clear water begins to drain from radiator.
15. Fill radiator with coolant up to specified level according to steps 3 through 12.

Coolant capacity (With reservoir tank):

6.6ℓ (7 US qt, 5-7/8 Imp qt)

Reservoir tank:

1.8ℓ (1-7/8 US qt, 1-5/8 Imp qt)

Regarding anti-freeze coolant mixture ratio, see MA-9.

16. Check for sound of coolant flow in heater core under the following conditions.
 - a. Running engine from idle up to 4,000 rpm.
 - b. Heater control lever (or switch) at "HOT" position.
 - If the sound can be heard, repeat steps 3 through 12 until the sound disappears.
17. Remove radiator cap and check coolant level.
 - If coolant level is low, refill radiator up to filler neck with coolant, and repeat steps 3 through 13 until coolant level become stable.
18. Close radiator cap and fill reservoir tank with coolant up to "MAX" level.
19. Position brake booster hose and install bolt for fitting brake booster hose bracket to intake manifold.
 - Clean excess coolant from engine.

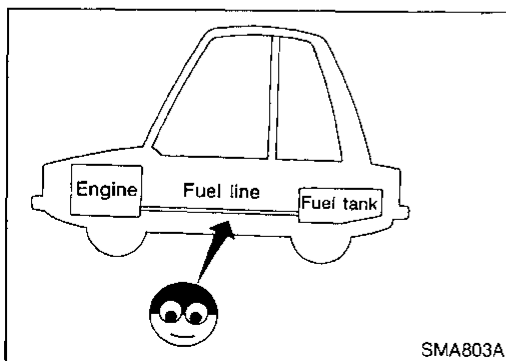

Checking Fuel Lines

Check fuel lines and tank for improper attachment, leaks, cracks, damage, loose connections, chafing and deterioration. If necessary, repair or replace faulty parts.

ENGINE MAINTENANCE

Checking Fuel Lines (Cont'd)

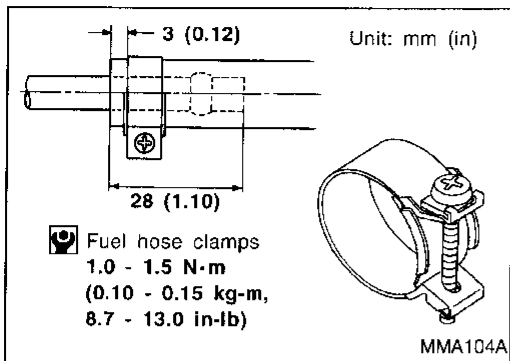

CAUTION:

Tighten high-pressure rubber hose clamp so that clamp end is 3 mm (0.12 in) from hose end.

Tightening torque specifications are the same for all rubber hose clamps.

Ensure that screw does not contact adjacent parts.

Changing Fuel Filter

WARNING:

Before removing fuel filter, release fuel pressure from fuel line.

1. Start engine.
2. Perform "FUEL PRESSURE RELEASE" in "WORK SUPPORT" mode to release fuel pressure to zero.
3. After engine stalls, crank engine two or three times to make sure that fuel pressure is released.
4. Turn ignition switch "OFF".

1. Remove fuel pump fuse.
2. Start engine.
3. After engine stalls, crank engine two or three times to make sure that fuel pressure is released.
4. Turn ignition switch "OFF" and install fuel pump fuse.

5. Loosen fuel hose clamps.
 6. Replace fuel filter.
- Be careful not to spill fuel over engine compartment. Place a shop towel to absorb fuel.
 - Use a high-pressure type fuel filter. Do not use a synthetic resinous fuel filter.
 - When tightening fuel hose clamps, refer to "Checking Fuel Lines".

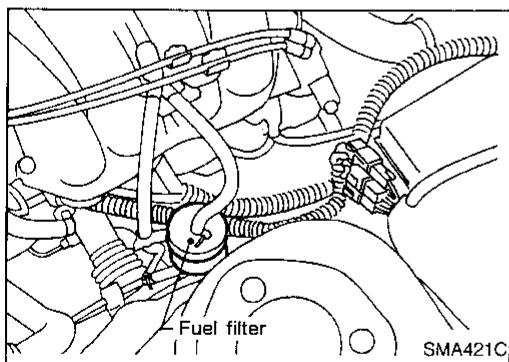
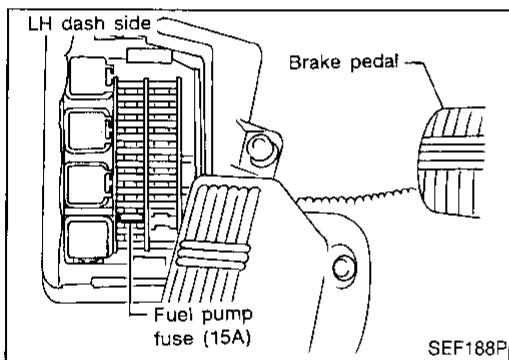
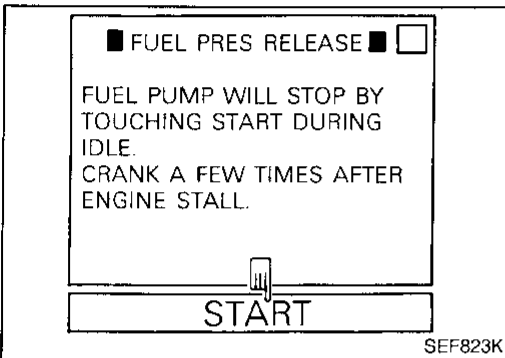

Changing Air Cleaner Filter

The viscous paper type filter does not need cleaning between renewals.

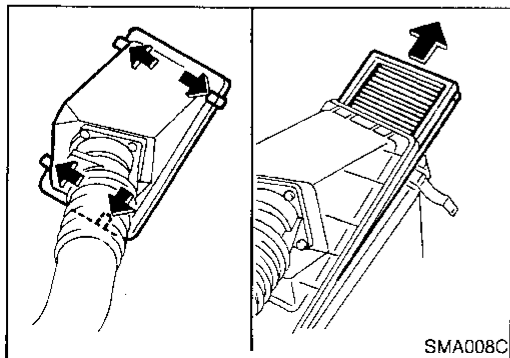

GI

MA

EM

LC

EC

FE

CL

MT

AT

PD

FA

RA

BR

ST

RS

BT

HA

EL

IDX

65

ENGINE MAINTENANCE

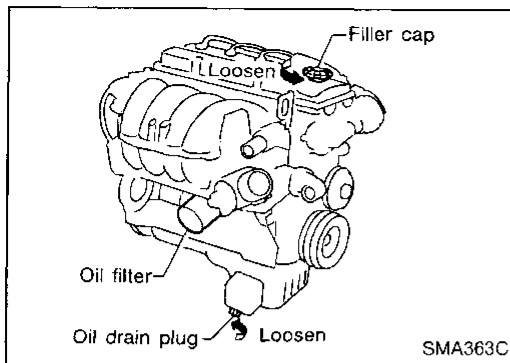

Changing Engine Oil

WARNING:

- Be careful not to burn yourself, as the engine oil is hot.
 - Prolonged and repeated contact with used engine oil may cause skin cancer; try to avoid direct skin contact with used oil. If skin contact is made, wash thoroughly with soap or hand cleaner as soon as possible.
1. Warm up engine, and check for oil leakage from engine components.
 2. Remove drain plug and oil filler cap.
 3. Drain oil and refill with new engine oil.

Oil specification and viscosity

- API SG or SH and Energy Conserving II
- API Certification Mark
- See "RECOMMENDED FLUIDS AND LUBRICANTS", MA-8.

Refill oil capacity (Approximately):

With oil filter change

3.8ℓ (4 US qt, 3-3/8 Imp qt)

Without oil filter change

3.5ℓ (3-3/4 US qt, 3-1/8 Imp qt)

CAUTION:

- Be sure to clean drain plug and install with new washer.
Drain plug:
: 29 - 39 N·m
(3.0 - 4.0 kg·m, 22 - 29 ft·lb)
- The refill capacity depends on the oil temperature and drain time; use the "Refill oil capacity" values as a reference and be certain to check with the dipstick when changing the oil.

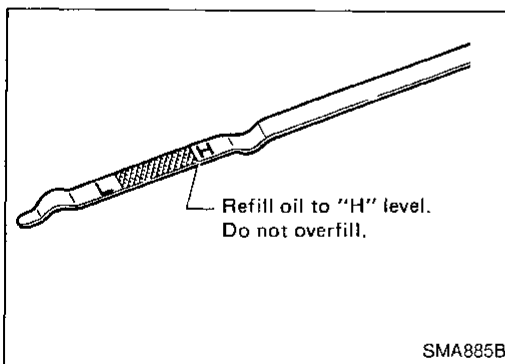

4. Check oil level.
5. Start engine and check area around drain plug and oil filter for oil leakage.
6. Run engine for a few minutes, then turn it off. After several minutes, check oil level.

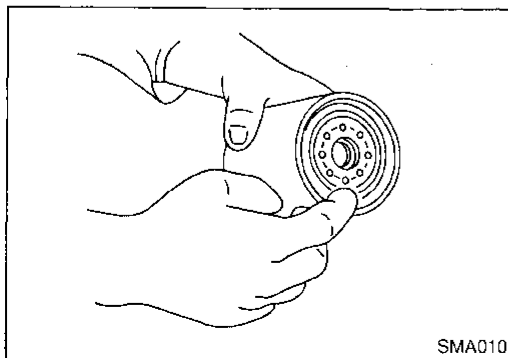

Changing Oil Filter

1. Remove oil filter with a suitable tool.

WARNING:

Be careful not to burn yourself, as the engine and the engine oil are hot.

2. Clean oil filter mounting surface on cylinder block. Coat rubber seal of new oil filter with engine oil.

ENGINE MAINTENANCE

Changing Oil Filter (Cont'd)

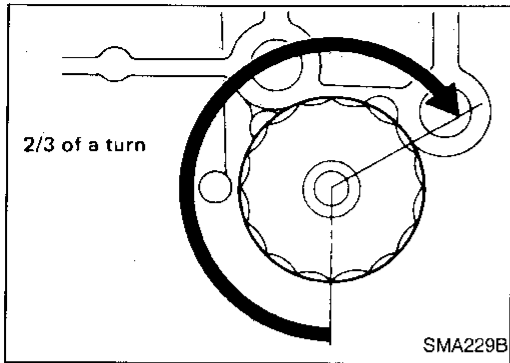

3. Screw in the oil filter until a slight resistance is felt, then tighten additionally 2/3 turn.

4. Add engine oil.

Refer to "Changing Engine Oil", MA-14.

- Clean excess oil from engine.

GI

MA

EM

Changing Spark Plugs

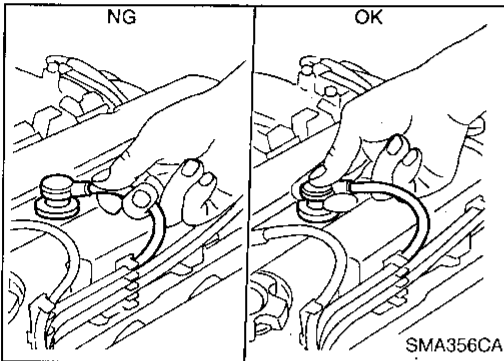

1. Disconnect ignition wires from spark plugs at boot. Do not pull on the wire.

LC

EC

FE

CL

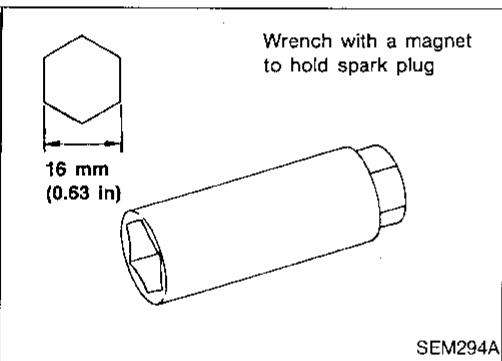

2. Remove spark plugs with suitable spark plug wrench.

Spark plug (Platinum-tipped type):

Make	NGK
Standard type	PFR5C-11
Cold type	PFR6C-11
	PFR7C-11

MT

AT

PD

Use standard type spark plug under normal conditions.

The cold type spark plug is suitable when spark knock occurs with the standard type spark plug under conditions such as:

- extended highway driving
- frequent high engine revolutions

Torque: 20 - 29 N·m
(2.0 - 3.0 kg-m, 14 - 22 ft-lb)

FA

RA

BR

ST

RS

BT

HA

EL

IDX

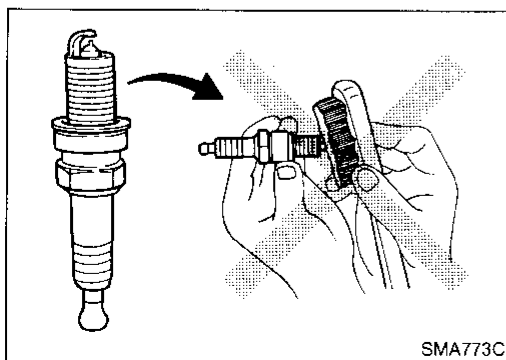

- Do not use a wire brush for cleaning.
- If plug tip is covered with carbon, spark plug cleaner may be used.

Cleaner air pressure:

Less than 588 kPa (6 kg/cm², 85 psi)

Cleaning time:

Less than 20 seconds

ENGINE MAINTENANCE

Changing Spark Plugs (Cont'd)

- Checking and adjusting plug gap is not required between change intervals.

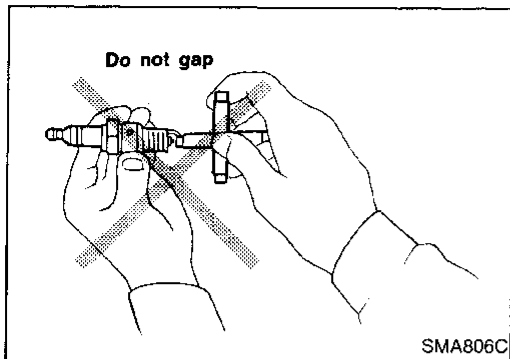

Checking EVAP Vapor Lines

1. Visually inspect EVAP vapor lines for improper attachment and for cracks, damage, loose connections, chafing and deterioration.
2. Inspect fuel tank filler cap vacuum relief valve for clogging, sticking, etc.

Refer to EC section ("EVAPORATIVE EMISSION SYSTEM").

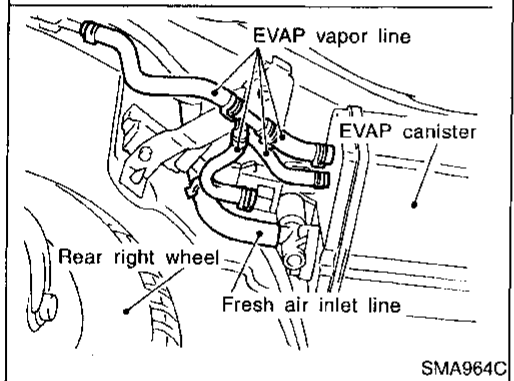
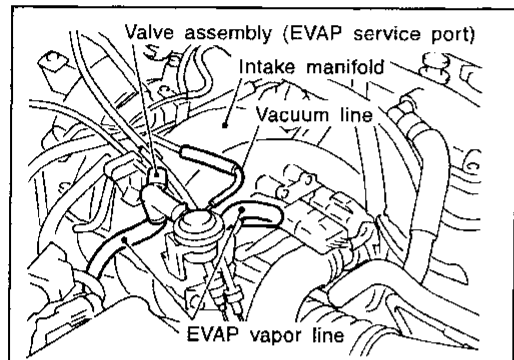

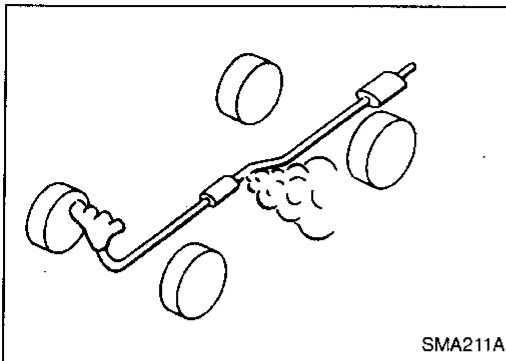

Checking Exhaust System

- Check exhaust pipes, muffler and mounting for improper attachment, leaks, cracks, damage, loose connections, chafing and deterioration.

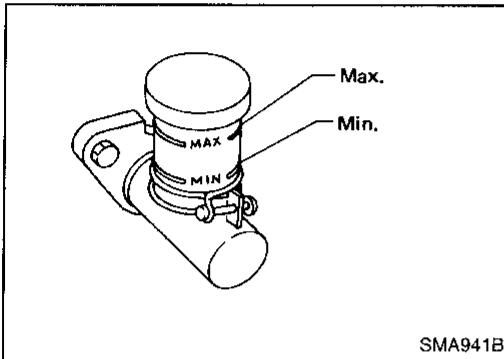

Checking Clutch Fluid Level and Leaks

- If fluid level is extremely low, check clutch system for leaks.

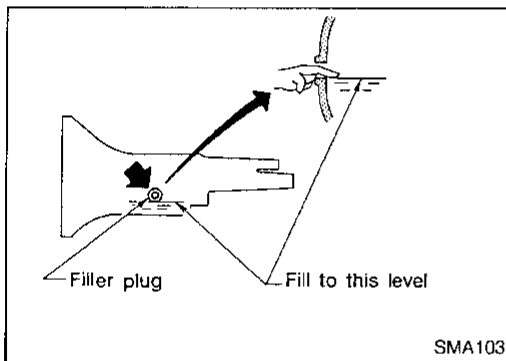

Checking M/T Oil

- Check for oil leakage and oil level.

Never start engine while checking oil level.

Filler plug:

⌚: 25 - 34 N·m (2.5 - 3.5 kg-m, 18 - 25 ft-lb)

Changing M/T Oil

1. Drain oil from drain plug and refill with new gear oil.
2. Check oil level.

Oil grade: API GL-4

Viscosity: See "RECOMMENDED FLUIDS AND LUBRICANTS", MA-8.

Capacity: 2.5ℓ (5-1/4 US pt, 4-3/8 Imp pt)

Drain plug:

⌚: 25 - 34 N·m (2.5 - 3.5 kg-m, 18 - 25 ft-lb)

After refilling oil, leave M/T unattended for about two minutes. Then check oil level again following the above procedure. Add oil if necessary.

GI

MA

EM

LC

EC

FE

CL

MT

AT

PD

FA

RA

BR

ST

RS

BT

HA

EL

IDX

CHASSIS AND BODY MAINTENANCE

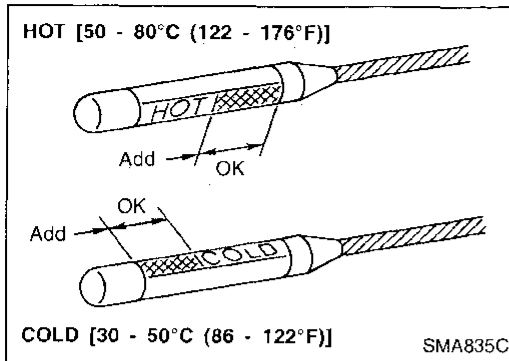

Checking A/T Fluid

1. Warm up engine.
2. Check for fluid leakage.
3. Before driving, fluid level can be checked at fluid temperatures of 30 to 50°C (86 to 122°F) using "COLD" range on dipstick.
 - a. Park vehicle on level surface and set parking brake.
 - b. Start engine and move selector lever through each gear position. Leave selector lever in "P" position.
 - c. Check fluid level with engine idling.
 - d. Remove dipstick and wipe clean with lint-free paper.
 - e. Re-insert dipstick into charging pipe as far as it will go.
 - f. Remove dipstick and note reading. If reading is at low side of range, add fluid to the charging pipe.

Do not overfill.

4. Drive vehicle for approximately 5 minutes in urban areas.
5. Re-check fluid level at fluid temperatures of 50 to 80°C (122 to 176°F) using "HOT" range on dipstick.

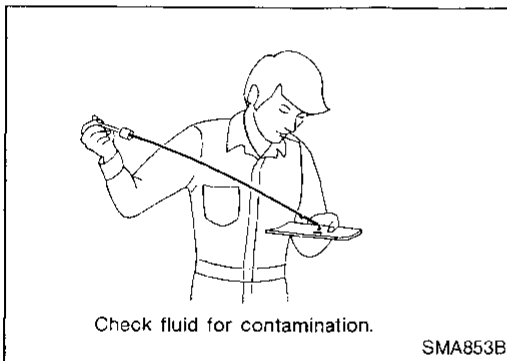

6. Check fluid condition.
 - If fluid is very dark or smells burned, refer to AT section for checking operation of A/T. Flush cooling system after repair of A/T.
 - If A/T fluid contains frictional material (clutches, bands, etc.), replace radiator and flush cooler line using cleaning solvent and compressed air after repair of A/T. Refer to LC section ("Radiator", "ENGINE COOLING SYSTEM").

Changing A/T Fluid

1. Warm up A/T fluid.
2. Stop engine.
3. Drain A/T fluid from drain plug and refill with new A/T fluid. Always refill same volume with drained fluid.

Fluid grade:

Nissan Matic "D" (Continental U.S. and Alaska) or Genuine Nissan Automatic Transmission Fluid (Canada)

Refer to "RECOMMENDED FLUIDS AND LUBRICANTS", MA-8.

Fluid capacity (With torque converter):

8.3ℓ (8-3/4 US qt, 7-1/4 Imp qt)

Drain plug:

Ⓐ: 29 - 39 N·m (3.0 - 4.0 kg·m, 22 - 29 ft·lb)

4. Run engine at idle speed for five minutes.
5. Check fluid level and condition. Refer to "Checking A/T Fluid". If fluid is still dirty, repeat step 2. through 5.

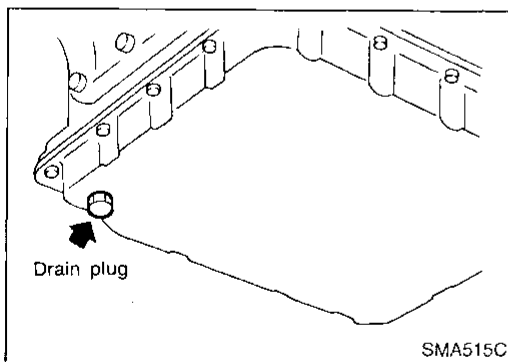

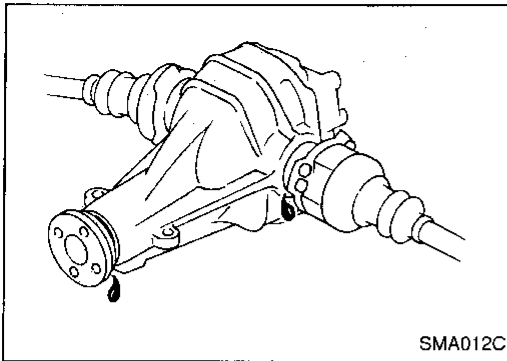

Checking Differential Gear Oil

- Check for oil leakage and oil level.
Filler plug:
: 39 - 59 N·m (4 - 6 kg·m, 29 - 43 ft·lb)

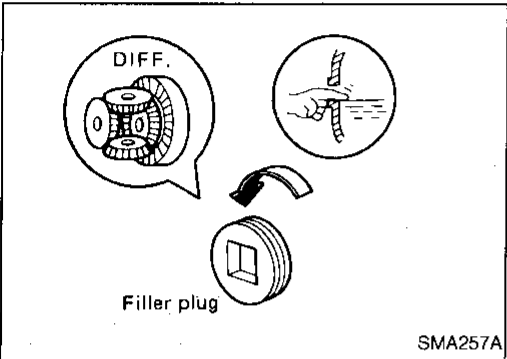

Changing Differential Gear Oil

1. Drain oil from drain plug and refill with new gear oil.
2. Check oil level.
Oil grade: API GL-5
Viscosity: See "RECOMMENDED FLUIDS AND LUBRICANTS", MA-8.
Capacity:
 1.2 - 1.4ℓ (2-1/2 - 3 US pt, 2-1/8 - 2-1/2 Imp pt)
Drain plug:
: 39 - 59 N·m (4 - 6 kg·m, 29 - 43 ft·lb)

Balancing Wheels

- Adjust wheel balance using road wheel center.
Wheel balance (Maximum allowable unbalance):
 Refer to SDS (MA-23).

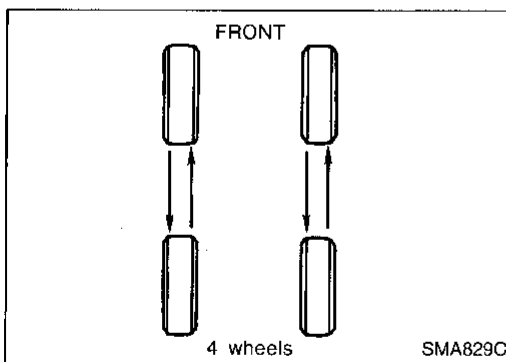

Tire Rotation

- Do not include the T-type spare tire when rotating the tires.
Wheel nuts:
: 98 - 118 N·m (10.0 - 12.0 kg·m, 72 - 87 ft·lb)

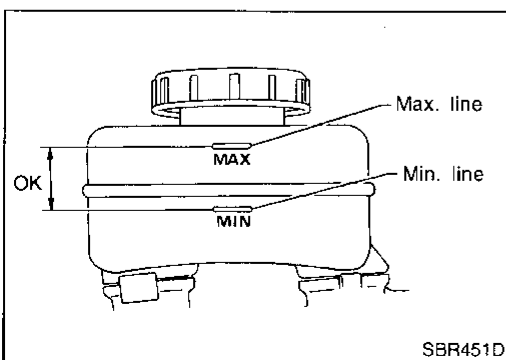

Checking Brake Fluid Level and Leaks

- If fluid level is extremely low, check brake system for leaks.

GI

MA

EM

LC

EC

FE

CL

MT

AT

PD

FA

RA

BR

ST

RS

BT

HA

EL

IDX

71

CHASSIS AND BODY MAINTENANCE

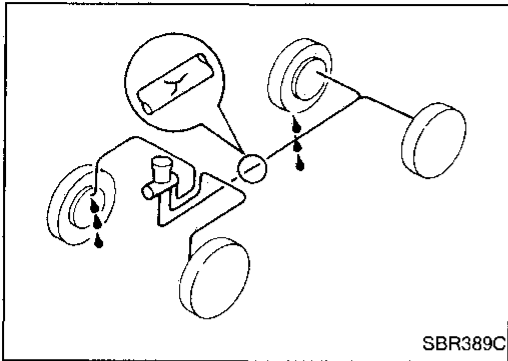

SBR389C

Checking Brake Lines and Cables

- Check brake fluid lines and parking brake cables for improper attachment, leaks, chafing, abrasions, deterioration, etc.

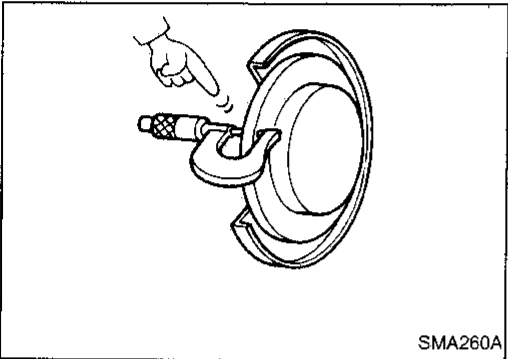

SMA260A

Checking Disc Brake

ROTOR

- Check condition and thickness.

Unit: mm (in)

	Front	Rear
Disc brake type	CL25VA	CL11H
Standard thickness	22.0 (0.866)	9.0 (0.354)
Minimum thickness	20.0 (0.787)	8.0 (0.315)

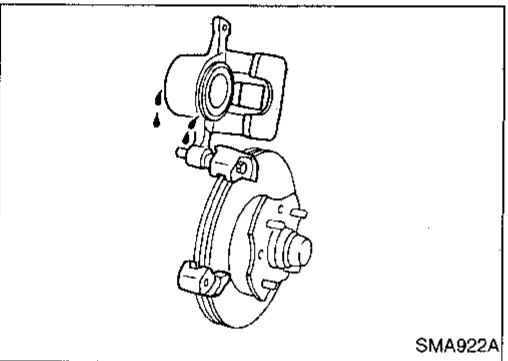

SMA922A

CALIPER

- Check for leakage.

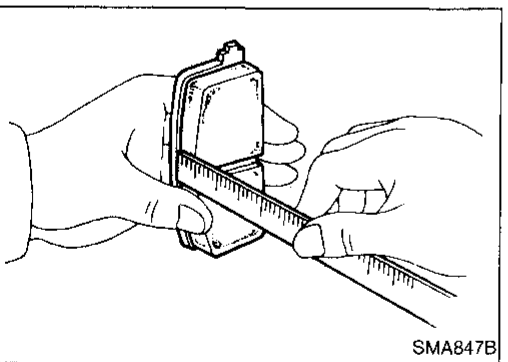

SMA847B

PAD

- Check for wear or damage.

Unit: mm (in)

	Front	Rear
Disc brake type	CL25VA	CL11H
Standard thickness	11.0 (0.433)	9.5 (0.374)
Minimum thickness	2.0 (0.079)	

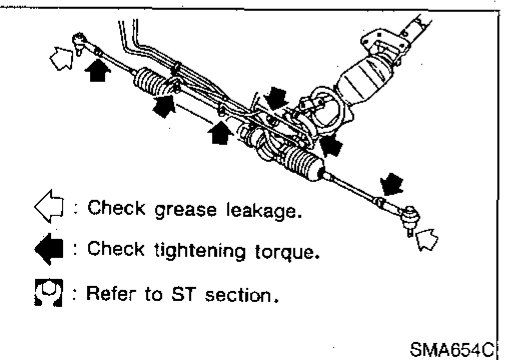

SMA654C

Checking Steering Gear and Linkage

STEERING GEAR

- Check gear housing and boots for looseness, damage or grease leakage.
- Check connection with steering column for looseness.

STEERING LINKAGE

- Check ball joint, dust cover and other component parts for looseness, wear, damage or grease leakage.

CHASSIS AND BODY MAINTENANCE

Checking Power Steering Fluid and Lines

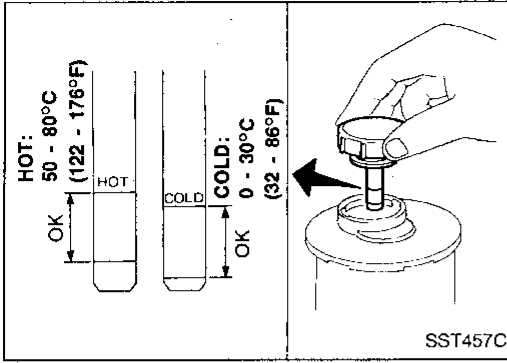

- Check fluid level with engine off.
- Check fluid level with dipstick on reservoir cap. Use "HOT" range at fluid temperatures of 50 to 80°C (122 to 176°F). Use "COLD" range at fluid temperatures of 0 to 30°C (32 to 86°F).

CAUTION:

- Do not overfill.
- Recommended fluid is Automatic Transmission Fluid type DEXRON™III or equivalent.

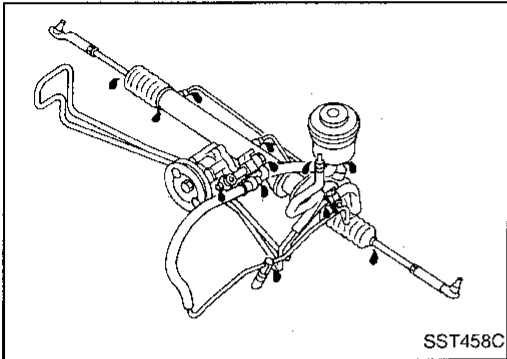

- Check lines for improper attachment, leaks, cracks, damage, loose connections, chafing or deterioration.
- Check rack boots for accumulation of power steering fluid.

GI

MA

EM

LC

EC

FE

CL

MT

AT

PD

FA

RA

BR

ST

RS

BT

HA

EL

IDX

CHASSIS AND BODY MAINTENANCE

Lubricating Locks, Hinges and Hood Latches

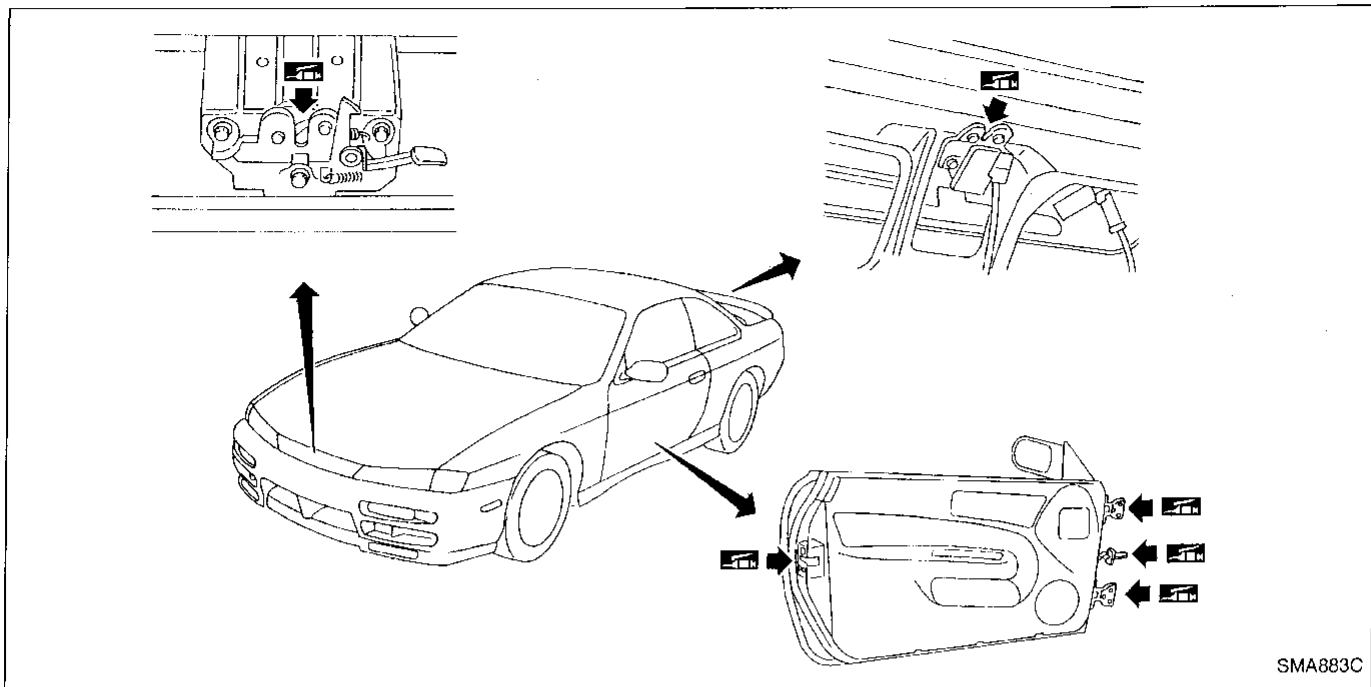

Checking Seat Belts, Buckles, Retractors, Anchors and Adjusters

CAUTION:

- After any collision, inspect all seat belt assemblies, including retractors and other attached hardware (i.e. guide rail set). Nissan recommends to replace all seat belt assemblies in use during a collision, unless not damaged and properly operating after minor collision. Also inspect seat belt assemblies not in use during a collision, and replace if damaged or improperly operating.
- If any component of seat belt assembly is questionable, do not repair. Replace as seat belt assembly.
- If webbing is cut, frayed, or damaged, replace belt assembly.
- Never oil tongue and buckle.
- Use a genuine seat belt assembly.

For details, refer to "Seat Belt Inspection", "SEAT BELTS" in RS section.

Anchor bolt

- 43 - 55 N·m
(4.4 - 5.6 kg-m,
32 - 41 ft-lb)

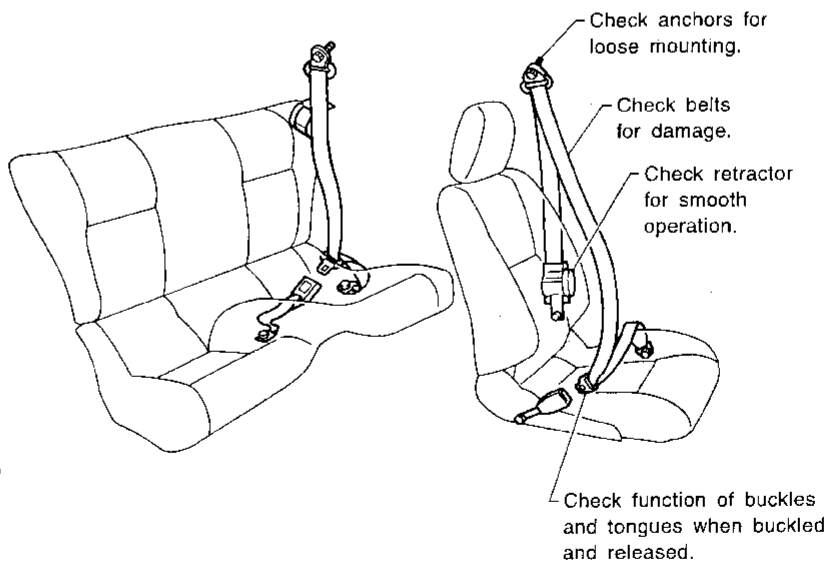

MMA094AC

SERVICE DATA AND SPECIFICATIONS (SDS)

Engine Maintenance

INSPECTION AND ADJUSTMENT

Drive belt deflection

Unit: mm (in)

	Used belt deflection		Deflection of new belt
	Limit	Deflection after adjustment	
Alternator	11 (0.43)	7 - 8 (0.28 - 0.31)	6 - 7 (0.24 - 0.28)
Air conditioner compressor	12 (0.47)	7.5 - 8.5 (0.295 - 0.335)	6.5 - 7.5 (0.256 - 0.295)
Power steering oil pump	13 (0.51)	7.5 - 8.5 (0.295 - 0.335)	6.5 - 7.5 (0.256 - 0.295)
Applied pushing force	98 N (10 kg, 22 lb)		

Spark plug

Standard type	PFR5C-11
Cold type	PFR6C-11
	PFR7C-11
Plug gap	1.0 - 1.1 mm (0.039 - 0.043 in)

GC

MA

EM

LC

EC

FE

Chassis and Body Maintenance

INSPECTION AND ADJUSTMENT

Wheel balance

Maximum allowable unbalance	Dynamic (at rim flange) g (oz)	10 (0.35) (One side)
	Static g (oz)	20 (0.71)

CL

MT

AT

PD

FA

RA

BR

ST

RS

BT

HA

EL

IDX